

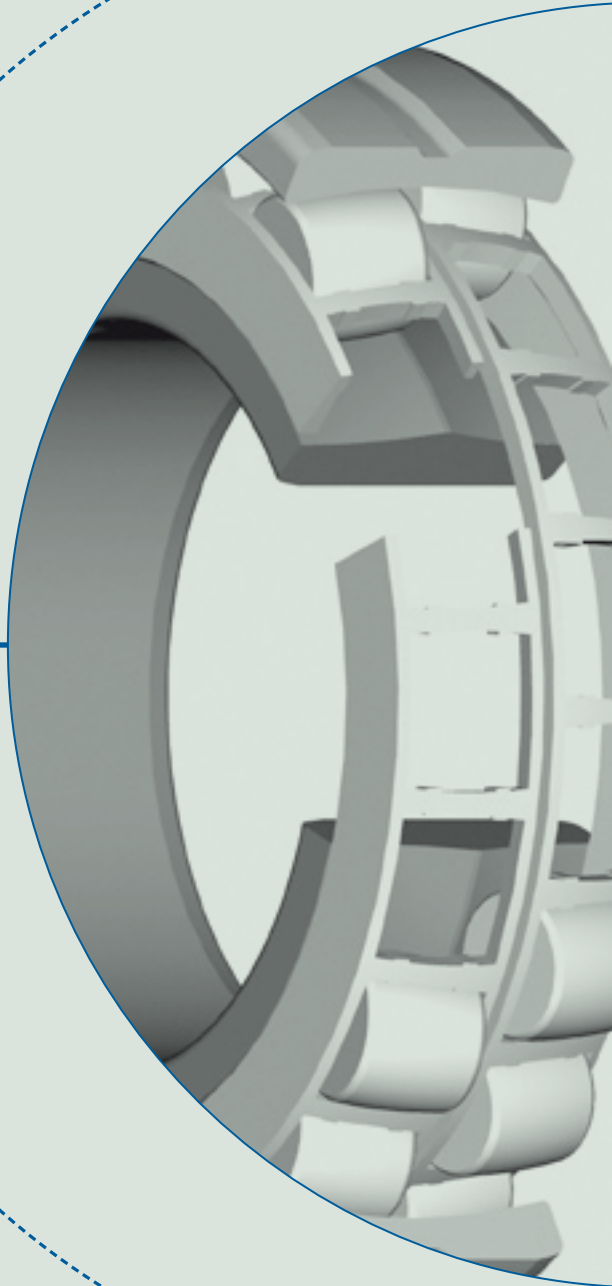

CONTENTS

Double Row Spherical Roller Bearings	003
Double Row Cylindrical Roller Bearings	039
Spherical Roller Thrust Bearings	043
Special Bearings	059



DOUBLE ROW SPHERICAL ROLLER BEARINGS

DOUBLE ROW SPHERICAL ROLLER BEARINGS

Double row spherical roller bearings have two rows of spherical rollers with common spherical raceway in outer ring. This internal bearing design enables mutual tilting of rings. Under load the spherical roller in some designs rest by their facial surface on fixed or floating center rib, guiding the rollers. Double row spherical roller bearings are not easily separable and are being mounted as a complete unit. They can accommodate great radial and simultaneously also axial loads in both directions. Double row spherical roller bearings have either cylindrical or tapered bore and are produced with steel sheet cage (J) or with machined brass cage (M).

Designation of Double Row Spherical Roller Bearings

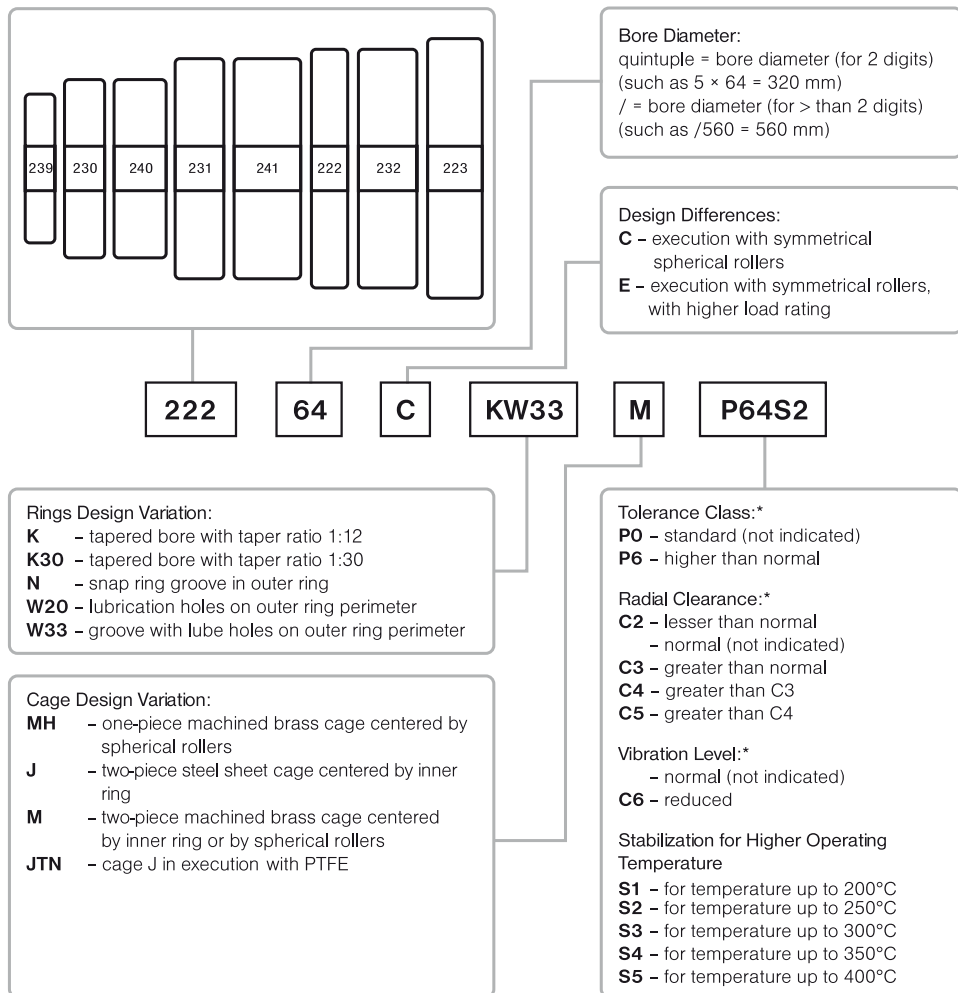

Note:

* Symbols of tolerance class, radial clearance and vibration level can be joined, such as $P6 + C4 + C6 = P646$.

All double row spherical roller bearings are designed and manufactured according to Czech CSN standards, which fully comply with the international standards ISO. Quality management system of the whole manufacturing process of double row spherical roller bearings is certified according to international standards series ISO 9000.

Double row spherical roller bearings are utilized in many industrial branches. For their specific properties they are particularly suitable in the following installations and mechanisms:

- gearboxes of trucks and heavy-duty construction, road building and mining machinery
- heavy-duty paper machines
- mountings of railway car axles and bogies, electric locomotives
- intricate mountings of tunnelling machines and shields, screening and sorting machines
- heavy engineering industry: presses, intricate turntables, heavy-duty machine tools, crushers, cranes
- metallurgical industry: rolling mills, converter mountings
- power industry: turbines, generators.

Boundary Dimensions

Boundary dimensions of double row spherical roller bearings shown in dimensional tables comply with international dimensional plan ISO. Manufacture of bearings of differing dimensions should be negotiated with the manufacturer first.

Review of Bearings Execution

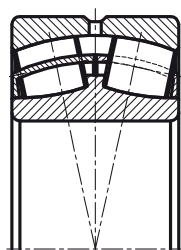

Type J

J Standard version of two-piece pressed steel sheet cage centered by inner ring

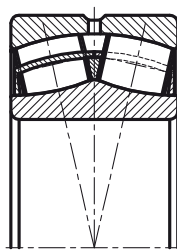

Type CJ

C bearing with symmetrical spherical rollers and with inner ring center floating rib
J two-piece pressed steel sheet cage centered by inner ring

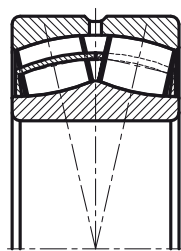

Type EJ

E bearing of higher basic load rating with symmetrical spherical rollers
J two-piece pressed steel sheet cage centered by inner ring and spherical rollers

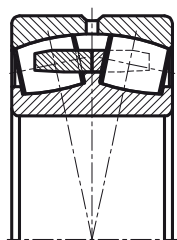

Type M

M two-piece machined brass cage centered by inner ring center rib

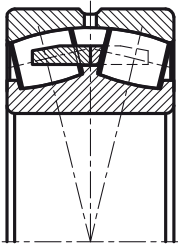

Type CM

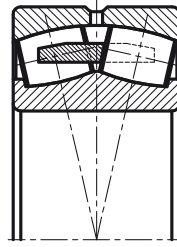

Type EMH

- C** bearing with symmetrical spherical rollers and center rest rib on inner ring
M two-piece machined brass cage centered by inner ring center rib

- E** bearing of higher basic load rating with symmetrical spherical rollers
MH one-piece machined brass ridge cage centered by spherical rollers

Groove and Lubricating Holes on Outer Ring

When double row spherical roller bearings are provided with a groove on perimeter and with three lubricating holes (W33), eventually three lubricating holes only (W20), the lubricant can be fed straight into the bearing between two spherical roller rows. This enables to achieve better lubrication and higher operating reliability.

Tolerance

Double row spherical roller bearings are commonly manufactured in normal tolerance class PO. This symbol is not shown in bearing designation. Manufacture of bearings of higher tolerance class should be negotiated with the manufacturer. Limiting deviation values of dimensions and run tolerances are shown in ISO 492.

Radial Clearance

Currently manufactured double row spherical roller bearings are of normal radial clearance, which is not shown in bearing designation. On client's request for special purpose arrangements these bearings may be manufactured with radial clearance C2 (lesser than normal) or with radial clearance C3, C4 or C5 (greater than normal). Clearances values are shown in the next tables.

Radial Clearance of Spherical Roller Bearings with Cylindrical Bore

Bore Diameter		Clearance									
d		C2		Normal		C3		C4		C5	
over	up to	min.	max.	min.	max.	min.	max.	min.	max.	min.	max.
mm		µm									
24	30	15	25	25	40	40	55	55	75	75	95
30	40	15	30	30	45	45	60	60	80	80	100
40	50	20	35	35	55	55	75	75	100	100	125
50	65	20	40	40	65	65	90	90	120	120	150
65	80	30	50	50	80	80	110	110	145	145	180
80	100	35	60	60	100	100	135	135	180	180	225
100	120	40	75	75	120	120	160	160	210	210	260
120	140	50	95	95	145	145	190	190	240	240	300
140	160	60	110	110	170	170	220	220	280	280	350
160	180	65	120	120	180	180	240	240	310	310	390
180	200	70	130	130	200	200	260	260	340	340	430
200	225	80	140	140	220	220	290	290	380	380	470
225	250	90	150	150	240	240	320	320	420	420	520
250	280	100	170	170	260	260	350	350	460	460	570
280	315	110	190	190	280	280	370	370	500	500	630
315	355	120	200	200	310	310	410	410	550	550	690
355	400	130	220	220	340	340	450	450	600	600	760
400	450	140	240	240	370	370	500	500	660	660	820
450	500	140	260	260	410	410	550	550	720	720	900
500	560	150	280	280	440	440	600	600	780	780	1000
560	630	170	310	310	480	480	650	650	850	850	1100
630	710	190	350	350	530	530	700	700	920	920	1190
710	800	210	390	390	580	580	770	770	1010	1010	1300
800	900	230	430	430	650	650	860	860	1120	1120	1440

Radial Clearance of Spherical Roller Bearings with Tapered Bore

24	30	20	30	30	40	40	55	55	75	-	-
30	40	25	35	35	50	50	65	65	85	85	105
40	50	30	45	45	60	60	80	80	100	100	130
50	65	40	55	55	75	75	95	95	120	120	160
65	80	50	70	70	95	95	120	120	150	150	200
80	100	55	80	80	110	110	140	140	180	180	230
100	120	65	100	100	135	135	170	170	220	220	280
120	140	80	120	120	160	160	200	200	260	260	330
140	160	90	130	130	180	180	230	230	300	300	380
160	180	100	140	140	200	200	260	260	340	340	430
180	200	110	160	160	220	220	290	290	370	370	470
200	225	120	180	180	250	250	320	320	410	410	520
225	250	140	200	200	270	270	350	350	450	450	570
250	280	150	220	220	300	300	390	390	490	490	620
280	315	170	240	240	330	330	430	430	540	540	680
315	355	190	270	270	360	360	470	470	590	590	740
355	400	210	300	300	400	400	520	520	650	650	820
400	450	230	330	330	440	440	570	570	720	720	910
450	500	260	370	370	490	490	630	630	790	790	1000
500	560	290	410	410	540	540	680	680	870	870	1100
560	630	320	460	460	600	600	760	760	980	980	1230
630	710	350	510	510	670	670	850	850	1090	1090	1360
710	800	390	570	570	750	750	960	960	1220	1220	1500
800	900	440	640	640	840	840	1070	1070	1370	1370	1690

Tapered Bore

Double row spherical roller bearings are manufactured either with cylindrical or with tapered bore (K) with taper ratio 1:12. Bearings with tapered bore are mounted either straight on tapered journal or on cylindrical journal by means of adapter sleeves or withdrawal sleeves. These bearings can also be supplied with tapered bore of taper ratio 1:30 (K30).

Self-Alignment

Double row spherical roller bearings can be tilted off the central position, without impairing their correct function. Values of permitted tilting are shown in the table:

Bearing Type	Permitted Tilting
239, 230, 231, 222	1°30'
223, 240	2°
232, 241	2°30'

Cages

Double row spherical roller bearings are manufactured in various design executions, with pressed steel sheet cages (J) , or machined brass cages (M) .Cages can be centered by rolling elements, by inner rings or by outer ring raceway. Upon client's request cages in other non-standard executions may also be supplied. Bearings in EJ and CJ execution can be delivered also with JTN design. This design increases limiting speed frequency by 10 %.

Bearings According to Special Technical Conditions

Bearings can also be manufactured according to special conditions agreed upon with the buyer. Such bearings are marked by supplementary designation TPF.

Connecting Surfaces Dimensions

Bearing rings may bear only on facial resting surface on the shaft or on the housing but not on the rounding. Maximum radius of connected parts r_a must therefore be smaller than the minimum dimension of rounding of bearing rings r_{\min} .

Operating Temperature Effect on Bearings Material

All spherical roller bearings pass special heat treatment permitting their use under operating temperature up to 200 °C without inadmissible dimensional changes.

Operating Temperature and Axial Load

Thanks to their inner design the bearings exposed to radial load can accommodate a sizeable axial load too. In case $F_a / F_r > e$ (see bearings tables), it is recommended to shorten the re-lubrication intervals in grease lubrication. Operating temperature may be a limiting factor as far as the axial load is concerned. In such a case we recommend to contact the Technical Consultation Services department of ZKL Vyzkum a vyvoj, a.s., who is prepared to evaluate suitability of selected bearing for particular operating conditions and mounting.

Axial Load Rating of Bearings Mounted on Adapter Sleeves

When mounting spherical roller bearings on plain shafts by means of adapter sleeves, the magnitude of axial load accommodated by the bearing depends on friction between the shaft and sleeve. Provided the bearings are properly mounted, we may calculate the permissible axial load from this relation:

$$F_{ap} = 3 \cdot B \cdot d$$

where

- F_{ap} . . . maximum permissible axial load [N]
- B . . . bearing width [mm]
- d . . . bearing bore diameter [mm]

Minimum Load

Rolling bearings with point and linear contact must be exposed to certain minimum load to secure their trouble-free operation. This applies to spherical roller bearings as well and particularly for operation at high speeds, when inertial forces of spherical rollers and of cage, plus friction in lubricant may have adverse influence on rolling and may result in damage of spherical rollers and of raceways. The needed minimum load for such cases can be estimated from this relation:

$$F_{rm} = 0,02 \cdot Cr$$

where

- F_{rm} . . . minimum radial load [N]
- Cr . . . basic dynamic load rating [N]

As a rule the mass of parts accommodated by the bearing along with external acting forces exceed the required minimum load. Should it not be the case, the bearing must be loaded by a supplementary force, such as by belt tightening, by higher torque at idle run or similar.

Dynamic Load

Basic Dynamic Load Rating

The basic dynamic load rating is a non-variable load under which the bearing reaches one million of revolutions. For radial bearings the basic radial load rating C_r refers to purely radial load (for thrust bearings the basic axial load rating C_a applies to purely axial load acting in bearing axis). Basic dynamic load rating magnitude depends on bearing dimension, number of rolling elements, bearing material and design. Values of basic dynamic load rating are specified in compliance with ISO 281.

Equivalent Dynamic Load

For calculation of the service life it is necessary first to convert the real acting load to equivalent load, i.e. imaginary constant load corresponding to preconditions for calculation of basic dynamic load ratings and having identical influence on bearing service life as a real acting load. Only then this load can be used for calculation of C / P relation. For correct calculation we must know most precisely the external forces acting on the bearing.

Radial Bearings

Radial equivalent dynamic load is an imaginary value which can be determined at combined load (at simultaneous radial and axial loads) by these equations:

$$P_{er} = F_r + Y_1 \cdot F_a \quad \text{for } F_a / F_r \leq e$$

$$P_{er} = 0,67 \cdot F_r + Y_2 \cdot F_a \quad \text{for } F_a / F_r > e$$

where

P_{er} ... radial equivalent dynamic load [N]

F_r ... radial load [N]

F_a ... axial load [N]

e, Y_1, Y_2 ... values of e, Y_1, Y_2 coefficients are shown in tabular part.

Static Load

Basic Static Load Rating

When a bearing is exposed to load at standstill or at very slow rotation, at oscillation or when a bearing is exposed to impacts and forces for a period shorter than one single revolution, we cannot define permissible bearing load by dynamic fatigue of functional surfaces but by permissible permanent deformations of raceways and of rolling elements. The values of basic radial static load rating C_{or} (and of basic axial static load rating C_{oa} for spherical roller thrust bearings) were determined in conformity with the international standard ISO 76. Basic static load rating is the load which causes total plastic deformation in the extent of $1 \cdot 10^{-4}$ of rolling element diameter in contact spot of the most loaded rolling element in central part of contact area between the rolling element and raceway. Under normal lubricating conditions this value corresponds to maximum contact load of approx. 4000 Mpa. The safety criterion regarding occurrence of extremely great plastic deformations is the safety coefficient at static load s_o .

$$s_o = \frac{C_{or}}{P_{oe}}$$

where

C_{or} ... basic radial static load rating [N]

P_{oe} ... equivalent static load [N]

s_o ... static safety

High value of static safety is advisable for bearings requiring easy revolving and smooth run; where lesser requirements of smooth run exist, lower s_o coefficient values will do.

Determination of s_o coefficient values is mostly based on practice and experience.

Equivalent Static Load

Relation of equivalent static load with real acting load and its definition is analogous as in equivalent dynamic load.

$$P_{oer} = F_r + Y_o F_a$$

where

P_{oer} ... radial equivalent static load [N]

F_r ... radial load [N]

F_a ... axial load [N]

Y_o ... value of Y_o coefficient is shown in tabular part.

Limiting Speed Frequency

Limiting Speed Frequency shown in catalogue table part is the maximum number of revolutions at which the

- bearing operates with a certain safety measure faultlessly under the following operating conditions:
- bearing load corresponds to service life $L_{10h} \cong 100\ 000$ hours
- axial element of forces magnitude F_a loading spherical roller radial bearing reaches 25% of radial component force F_r at maximum
- bearings are manufactured with normal tolerance class, with normal radial clearance
- limiting speed frequency for oil lubrication is understood for oil bath lubrication.

If the bearing operates at a higher load than above, it is necessary to rectify the limiting speed frequency. For instance, if the bearing load corresponds to bearing service life $L_{10h} = 20\ 000$ hours, the limiting speed frequency value should be reduced by 3 to 28 percent depending on bearing size (smaller bearings need minor correction); when the load corresponds to service life of $L_{10h} = 5\ 000$ hours, the rectification of limiting speed frequency ranges between 10 to 65 percent.

Similarly the limiting speed frequency must be reduced if axial load magnitude of radial bearings exceeds 25 percent of force radial element. For instance, if $F_a / F_r = 0.6$, the limiting speed frequency has to be reduced by 10%, if $F_a / F_r = 2$, the limiting speed frequency should be reduced by 26%.

On the other hand, the catalogue limiting speed frequency may be exceeded under certain conditions. For example, limiting speed frequency of spherical roller radial bearing may be increased, provided these conditions are adhered to:

- bearing load and F_a values correspond to catalogue operating conditions ($L_{10h} = 100\ 000$ hours, relation F_a / F_r does not exceed the value of 2.5)
- adequately efficient oil circulation lubrication is secured
- the bearing and all parts relating to it are manufactured with higher accuracy
- the bearing of higher radial clearance (C3) is used.

Whenever the value of limiting speed frequency of bearings, operating under other conditions than that ruling for limiting speed frequency shown in catalogue table part, needs to be determined, we recommend to consult Technical and Consulting Services department of ZKL – Vyzkum a vyvoj, a. s. for advice.

Lubrication of Bearings

Grease Lubrication

Lubrication by grease has a number of practical advantages in comparison with oil lubrication and therefore it is preferred wherever this lubrication method can be applied. As a rule mounting designs of bearings lubricated by grease are simple, costs of sealing the bearing space are lower than for oil lubrication and risk of lubricant escape is not so great compared with oil lubrication.

At first mounting the inner bearing space is filled by grease fully, while the free space round the bearing is filled just to one third and not more than to its half. In order to prevent possible contamination or other degradation of lubricant in the process of mounting we recommend to lubricate the bearings only after fitting is finished, whenever possible.

Grease will lose its lubricating properties after certain time. Main factors influencing grease life are:

- lubricant quality
- bearing size
- operating speed
- operating temperature
- working environment

It is therefore necessary to re-lubricate the bearings regularly. The recommended re-lubrication interval length t_f can be read in the following graph specifying its value in dependence to operating speed n and bearing bore diameter d . This diagram applies to these operating conditions:

- bearing load does not exceed 15 percent of basic dynamic load rating
- grease of standard quality is used
- bearing outer ring operating temperature is 70 °C at maximum
- bearing in mounted on horizontal shaft.

If operating temperature exceeds 70 °C, the re-lubrication interval becomes shorter – to its half for each 15 °C exceeding 70 °C temperature. Contrary to it, at a temperature below 40 °C it is possible to lengthen the re-lubrication interval twice as much. In respect of bearings fitted on vertical shafts we recommend to reduce t_f shown in diagram to its half.

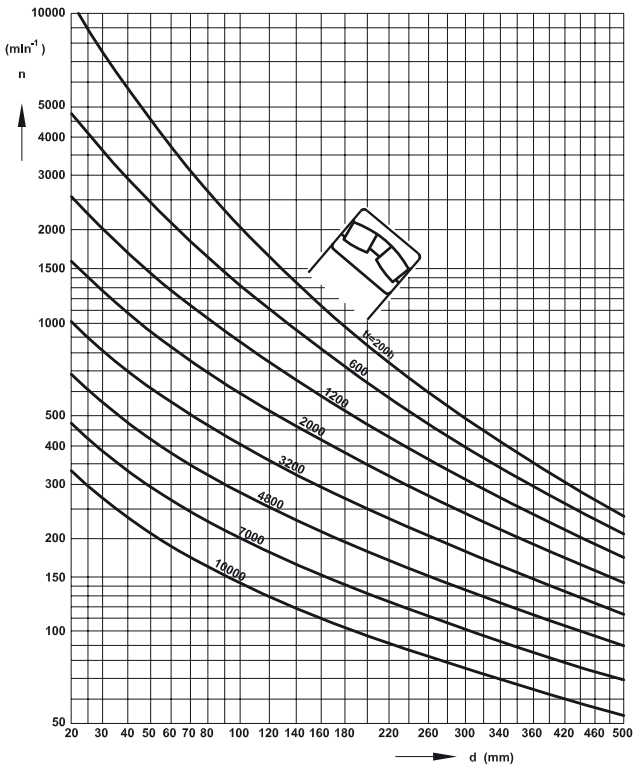

Lubricant quantity Q needed for bearing re-lubrication can be determined either according to the instruction of manufacturer of the equipment in which the bearing is installed, or according to the following relation:

$$Q = 0.005 \cdot D \cdot B$$

where

- Q ... lubricant quantity [g]
- D ... outer bearing diameter [mm]
- B ... bearing width [mm]

Best method of grease application into the bearing is the use of a lubricating device – grease gun. In respect of W33 bearings the most convenient way (provided the mounting arrangement allows it) is to apply grease through outer ring holes.

When a bearing operates at a rather high speed, i.e. frequent re-lubrication is needed, a risk of lubricant stacking in bearing space exists. Such lubricant should be removed after a certain time. For this purpose so called lubricant slinger being a part of mounting design usefully serves. When using lubricant slinger with new series of spherical roller bearings operating at higher speeds a rich lubrication must be applied at the operation start. One hour after new bearing start and 24 hours after again a triple grease quantity should be applied.

Important note: always use the same type of grease at re-lubrication as that applied in the bearing originally. Never mix different greases unless you are sure of their compatibility. Since mixing of various greases cannot be absolutely excluded in regular practice, we may use with relatively no consequences the mixtures of:

- greases with identical thickener
- lithium / calcium soap based greases
- calcium / bentonite based greases.

Combinations of following greases are inappropriate:

- sodium / lithium
- sodium / calcium
- sodium / aluminum
- sodium / bentonite
- aluminum / bentonite.

When mixing such greases their structure may become altered, in addition to that acute softening of the grease may occur. Should there exist the necessity to change to another type of grease, re-lubrication must be made by a great quantity of lubricant (grease flushing) whenever the mounting design allows it. Next re-lubrication has to be made at a shorter time interval.

Overview of grease is shown in the table:

Grease Type		Properties		
Thickener	Base Oil	Operating Temp. Range [°C]	Water Resistance	Application
Lithium soap	Mineral	-20 ÷ 130	Resistant	All-purpose lubricant
Calcium soap	Mineral	-20 ÷ 50	Very resistant	Good water sealant
Sodium soap	Mineral	-20 ÷ 100	Non-resistant	Emulsifies with water
Aluminum soap	Mineral	-20 ÷ 70	Resistant	Good water sealant
Complex lithium soap	Mineral	-20 ÷ 130	Resistant	All-purpose lubricant
Complex calcium soap	Mineral	-30 ÷ 130	Very resistant	All-purpose lubricant, suitable for higher temperatures and loads
Complex sodium soap	Mineral	-20 ÷ 130	Resistant	Suitable for higher temp. and loads
Complex aluminum soap	Mineral	-20 ÷ 150	Resistant	Suitable for higher temp. and loads
Complex barium soap	Mineral	-30 ÷ 140	Resistant	Suitable for higher temp. and loads
Bentonite	Mineral	-20 ÷ 150	Resistant	Suitable for high temperatures at low speed frequency
Polyurea	Mineral	-20 ÷ 160	Resistant	Suitable for high temperatures at medium speed frequency
Lithium soap	Silicone	-40 ÷ 170	Very resistant	Suitable for wide temperature range at medium speed frequency
Complex barium soap	Ester	-60 ÷ 140	Resistant	Suitable for higher temperatures and higher speed frequency

Oil Lubrication

Lubrication of bearings by oil is used mostly in following cases:

- re-lubrication intervals by grease are too short
- bearing operating temperature is too high and thus use of grease is unsuitable
- the entire unit (such as the gearbox) is lubricated by oil.

Spherical roller bearings are lubricated either by oil bath lubrication, when oil level is maintained in the height of the bearing lowest rolling element center, or by oil circulation lubrication. As a rule rolling bearings are lubricated by mineral oils of good chemical stability. Appropriate mineral oil reference viscosity ν_1 is determined from the next diagram, in dependence on bearing mean diameter:

$$d_s = (D + d) / 2$$

where

- d_s . . . bearing mean diameter [mm]
- D . . . bearing outer diameter [mm]
- d . . . bore diameter [mm]

If operating temperature t of the bearing is known or can be established, we can determine the operating viscosity ν at internationally standardized reference temperature of 40°C, needed for calculation of viscosity ratio:

$$\kappa = \nu / \nu_1$$

where

- κ . . . viscosity ratio
- ν . . . operating viscosity [mm².s⁻¹]
- ν_1 . . . reference viscosity [mm².s⁻¹]

If κ is smaller than 1, it is advisable to use oils with so-called EP additives to prevent caking of metallic parts in the contact point at local temperature rise). When κ value falls below 0.4, the use of oil with EP additives is inevitable.

Graph for Determination of Operative Viscosity

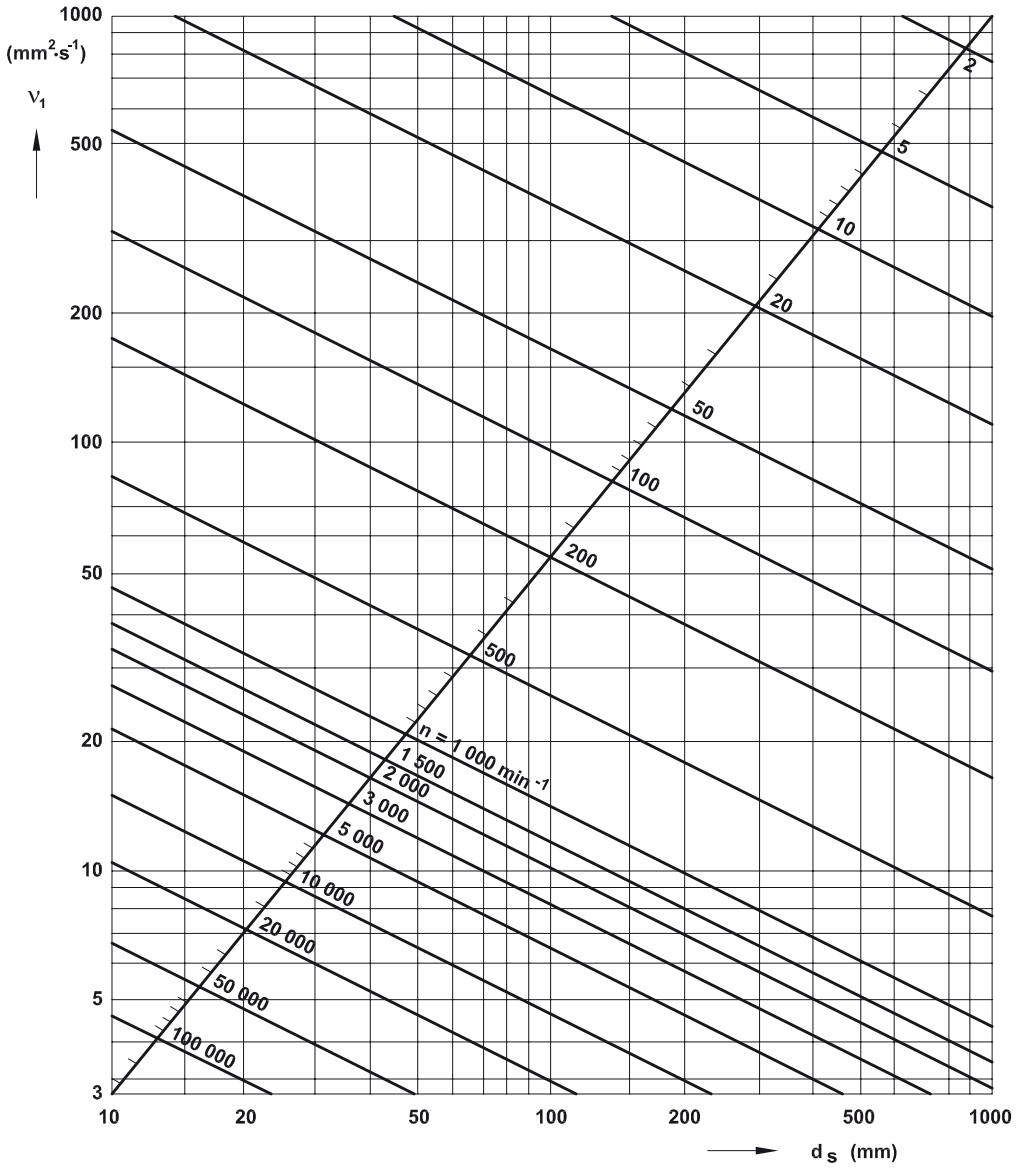

Graph for Determination of Kinematic Viscosity

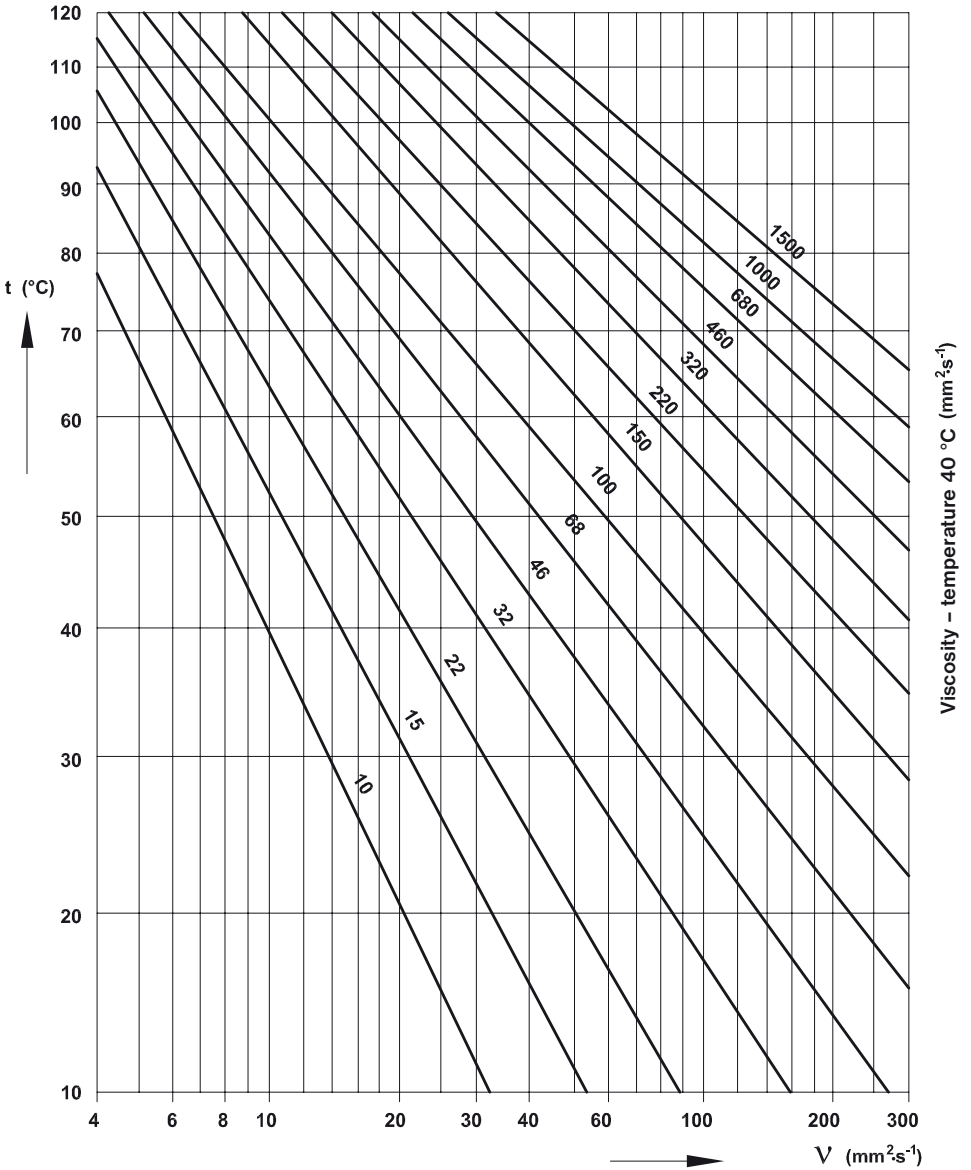

Mounting and Dismounting of Spherical Roller Bearings

Workplace cleanness, i.e. both cleanness of bearings and lubricant and of further components of the mounting and of mounting devices, is the principal prerequisite of correct mounting and dismounting. Bearings should be removed from their protective packing not until but shortly before mounting.

Mounting of Bearings with Cylindrical Bore

Bearings may be mounted on journals or into housings bores either under cold or hot mounting process. It is recommended to cold mount rather smaller bearings. The force necessary for mounting is applied either by a press or by hammer strokes. We recommend the use a mechanical or hydraulic press instead of striking, wherever possible. In both cases an assembly jig should be applied on bearing ring just installed; direct strikes must not be thrown on bearing rings! The installing force must not be transferred over rolling elements. The tube-shape assembly jig should lean on the ring being mounted, eventually on both rings simultaneously.

Force needed for mounting grows with the bearing size and therefore larger bearings must be hot mounted.

The most frequent heating methods are

- in oil bath
- induction heating
- in heating furnace.

Bearings are heated to the temperature of maximum 100 °C. Heating the bearings by welding equipment open flame is prohibited.

Mounting of Bearings with Tapered Bore

Bearings with tapered bore are fitted on the shaft by adapter or withdrawal sleeves, or directly on tapered journal.

Sufficiently reliable fitting of inner ring is checked at mounting by measuring of reduced bearing radial clearance (using feeler gauges), or by measurement of inner ring axial offset length on the journal or on adapter / withdrawal sleeve. The initial position for measurement of axial offset is such position at which contact surfaces of the ring and of the shaft (or journal) seat against each other on the whole seating surface. The values needed for mounting are shown in the next table.

Inner rings may be installed in following ways:

- by striking the assembly sleeve
- by means of KM nut and assembly spanner
- by means of special hydraulic nut
- by hot mounting.

Bearings with tapered bore are mounted on the shaft always with an offset. The offset magnitude is measured either by reduced radial clearance of mounted bearing or by axial displacement of the inner ring on tapered journal. In respect of double row spherical roller bearings we recommend to measure the radial clearance decrease (reduction). Simple checking the axial displacement (offset) is allowed for small size bearings or in limited space conditions, anyhow this requires good experience to define the initial starting position. For measurement of radial clearance before, during and after installation the common feeler gauges are used. Clearance should be measured between outer ring raceway and unloaded spherical roller in upper part of the bearing. Prior to measuring the bearing should be turned repeatedly so that the rollers settle down to correct position. When measuring, press the spherical roller slightly to centering ring (according to design solution) between both roller rows. The measured radial clearance value must be identical for both rows of spherical rollers. Recommended values of radial clearance reduction and of axial offset for spherical roller bearings with tapered bore are shown in the next table. If this recommendation is adhered to, the offset is fully adequate (particularly for reaching the upper limit of radial clearance reduction), see table.

Recommended Values of Radial Clearance Reduction and of Inner Ring Axial Offset for Mounting of Double Row Spherical Roller Bearings with Tapered Bore of 1:12 and 1:30 Tapered Ratio

Bore Diameter d		Radial Clearance Reduction		Axial Offset ΔL on Taper 1:12				Axial Offset ΔL on Tape 1:30				Minimum Permissible Residual Clearance after Mounting of Bearings with Initial Clearance		
				Shaft		Sleeve		Shaft		Sleeve				
Over	Up to	Min.	Max.	Min.	Max.	Min.	Max.	Min.	Max.	Min.	Max.	Norm.	C3	C4
mm		μm		μm				μm				μm		
24	30	15	20	300	350	300	400					15	20	35
30	40	20	25	350	400	350	450					15	25	40
40	50	25	30	400	450	450	500					20	30	50
50	65	30	40	450	600	500	700					25	35	55
65	80	40	50	600	750	700	850					25	40	70
80	100	45	60	700	900	750	1000	1700	2200	1800	2400	35	50	80
100	120	50	70	700	1100	800	1200	1900	2700	2000	2800	50	65	100
120	140	65	90	1100	1400	1200	1500	2700	3500	2800	3600	55	80	110
140	160	75	100	1200	1600	1300	1700	3000	4000	3100	4200	55	90	130
160	180	80	110	1300	1700	1400	1900	3200	4200	3300	4600	60	100	150
180	200	90	130	1400	2000	1500	2200	3500	4500	3600	5000	70	100	160
200	225	100	140	1600	2200	1700	2400	4000	5500	4200	5700	80	120	180
225	250	110	150	1700	2400	1800	2600	4200	6000	4600	6200	90	130	200
250	280	120	170	1900	2600	2000	2900	4700	6700	4800	6900	100	140	220
280	315	130	190	2000	3000	2200	3200	5000	7500	5200	7700	110	150	240
315	355	150	210	2400	3400	2600	3600	6000	8200	6200	8400	120	170	260
355	400	170	230	2600	3600	2900	3900	6500	9000	6800	9200	130	190	290
400	450	200	260	3100	4100	3400	4400	7700	10000	8000	10400	130	200	310
450	500	210	280	3300	4400	3600	4800	8200	11000	8400	11200	160	230	350
500	560	240	320	3700	5000	4100	5400	9200	12500	9600	12800	170	250	360
560	630	260	350	4000	5400	4400	5900	10000	13500	10400	14000	200	290	410
630	710	300	400	4600	6200	5100	6800	11500	15500	12000	16000	210	310	450
710	800	340	450	5300	7000	5800	7600	13300	17500	13600	18000	230	350	510
800	900	370	500	5700	7800	6300	8500	14300	19500	14800	20000	270	390	570
900	1000	410	550	6300	8500	7000	9400	15800	21000	16400	22000	300	430	640
1000	1120	450	600	6800	9000	7600	10200	17000	23000	18000	24000	320	480	700

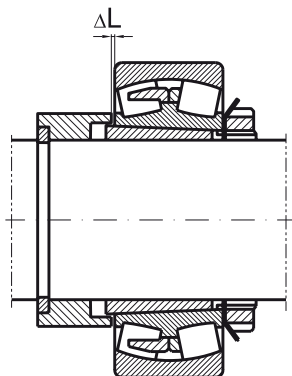

Dismounting of Bearings

Bearings with cylindrical bore are dismounted by using mechanical pullers (in case of small and medium sized bearings) or by pressure oil (medium and large bearings). As for the bearings fitted on tapered journal, mechanical pullers serve for small bearings dismounting only while medium sized and large bearings need pressure oil. Small and medium sized bearings fitted on adapter sleeve are removed by withdrawal sleeve, for medium sized and large bearings fitted on adapter sleeves special hydraulic nut should be used. Small and medium sized bearings fitted on withdrawal sleeves are dismounted by means of KM nut and mounting spanner, for large bearings special hydraulic nut should be used.

DOUBLE ROW SPHERICAL ROLLER BEARINGS

d = 25 to 65 mm

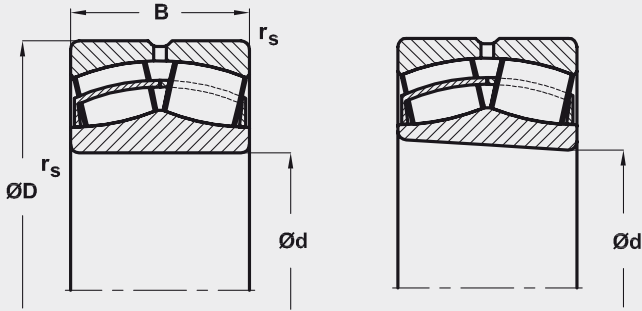

Dimensions				Basic Load Rating		Limiting Speed Frequency for Lubrication		Mass		Cylindrical Bore Bearing Designation
d	D	B	r _s	C _r	C _{0r}	by Grease	by Oil	Cylindrical Bore	Tapered Bore	
mm				kN		min ⁻¹		kg		
25	52	18	1	46	46.1	8500	11000	0.16	0.155	22205EW33J
30	62	20	1	60.9	64.5	7500	9500	0.25	0.245	22206EW33J
35	72	23	1.1	80.7	92	6300	8000	0.42	0.41	22207EW33J
40	80	23	1.1	93.1	105	6000	7500	0.51	0.5	22208EW33J
40	90	33	1.5	132	149	4100	5100	1.07	1.05	22308EW33J
40	90	33	1.5	132	149	4100	5100	1.07	1.05	22308EW33MH*
45	85	23	1.1	97.3	113	5300	6700	0.55	0.53	22209EW33J
45	100	36	1.5	159	182	3700	4600	1.43	1.4	22309EW33J
45	100	36	1.5	159	182	3700	4600	1.43	1.4	22309EW33MH*
50	90	23	1.1	105	124	5000	6300	0.59	0.57	22210EW33J
50	110	40	2	191	225	3300	4000	1.92	1.88	22310EW33J
50	110	40	2	191	225	3300	4000	1.92	1.88	22310EW33MH*
55	100	25	1.5	124	148	4500	5600	0.78	0.76	22211EW33J
55	120	43	2	230	279	3000	3800	2.4	2.3	22311EW33J
55	120	43	2	221	264	3000	3800	2.45	2.4	22311EW33MH*
60	110	28	1.5	140	174	4000	5000	1.07	1.05	22212EW33J
60	130	46	2.1	273	315	2800	3600	2.9	2.8	22312EW33J
60	130	46	2.1	209	230	2800	3300	3	2.9	22312W33M*
65	120	31	1.5	177	216	3800	4800	1.45	1.42	22213EW33J
65	140	48	2.1	304	351	2600	3400	3.5	3.4	22313EW33J
65	140	48	2.1	222	252	2700	3200	3.6	3.5	22313W33M*

Notice: Deliveries of bearings marked * need to be negotiated with manufacturer

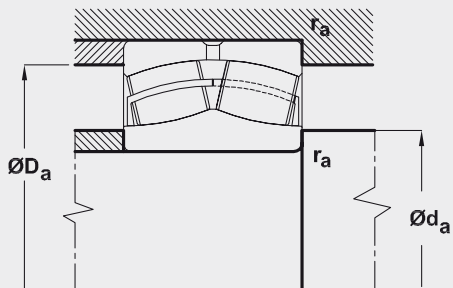

Tapered Bore Bearing Designation	Connecting Dimensions			Adapter Sleeve	Withdrawal Sleeve	Withdrawal Nut	Calculation Coefficients				
	d_a	D_a	r_a				e	Y_1	Y_2	Y_0	
	min	max	max								
	mm										
22205EKW33J	30	47	1	H305	AH305	KM6	0.34	2	3	2	
22206EKW33J	35	57	1	H306	AH306	KM7	0.31	2.1	3.2	2.1	
22207EKW33J	42	65	1	H307	AH307	KM8	0.31	2.2	3.3	2.1	
22208EKW33J	47	73	1	H308	AH308	KM9	0.27	2.5	3.7	2.4	
22308EKW33J	47	81	1.5	H2308	AH2308	KM9	0.36	1.8	2.6	1.8	
22308EKW33MH	47	81	1.5	H2308	AH2308	KM9	0.36	1.8	2.6	1.8	
22209EKW33J	52	78	1	H309	AH309	KM10	0.26	2.6	3.9	2.6	
22309EKW33J	52	91	1.5	H2309	AH2309	KM10	0.35	1.7	2.7	1.8	
22309EKW33MH	52	91	1.5	H2309	AH2309	KM10	0.35	1.7	2.7	1.8	
22210EKW33J	57	83	1.2	H310	AH310X	KM11	0.24	2.8	4.2	2.8	
22310EKW33J	60	100	2	H2310	AH2310X	KM11	0.36	1.9	2.7	1.8	
22310EKW33MH	60	100	2	H2310	AH2310X	KM11	0.36	1.9	2.7	1.8	
22211EKW33J	62	91	1.5	H311	AH311X	KM12	0.23	2.9	4.4	2.9	
22311EKW33J	65	110	2	H2311	AH2311X	KM12	0.35	1.9	2.8	1.9	
22311EKW33MH	65	110	2	H2311	AH2311X	KM12	0.35	1.9	2.7	1.8	
22212EKW33J	67	101	1.5	H312	AH312X	KM13	0.24	2.8	4.2	2.8	
22312EKW33J	72	118	2	H2312	AH2312X	KM13	0.35	1.9	2.9	1.9	
22312KW33M	72	118	2	H2312	AH2312X	KM13	0.41	1.6	2.4	1.6	
22213EKW33J	72	111	1.5	H313	AH313	KM15	0.24	2.9	4.2	2.8	
22313EKW33J	76	128	2	H2313	AH2313	KM15	0.34	2	3	2	
22313KW33M	76	128	2	H2313	AH2313	KM15	0.38	1.8	2.5	1.7	

DOUBLE ROW SPHERICAL ROLLER BEARINGS

d = 70 to 90 mm

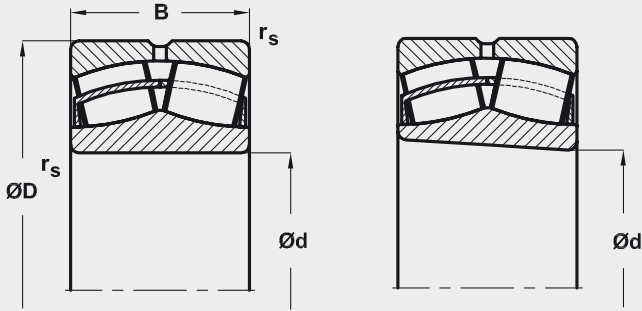

Dimensions				Basic Load Rating		Limiting Speed Frequency for Lubrication		Mass		Cylindrical Bore Bearing Designation
d	D	B	r _s	C _r	C _{0r}	by Grease	by Oil	Cylindrical Bore	Tapered Bore	
mm				kN		min ⁻¹		kg		
70	125	31	1.5	189	239	3600	4500	1.61	1.57	22214EW33J
70	150	51	2.1	344	402	2400	3100	4.2	4.1	22314EW33J
70	150	51	2.1	289	330	2400	3000	4.3	4.2	22314W33M*
75	130	31	1.5	196	255	3400	4300	1.7	1.66	22215EW33J
75	160	55	2.1	396	489	2300	3000	5.3	5.2	22315EW33J
75	160	55	2.1	295	354	2200	2800	5.4	5.2	22315W33M*
80	140	33	2	224	295	3200	4000	2.11	2.07	22216EW33J
80	140	33	2	154	197	2400	3000	2.2	2.1	22216W33M*
80	170	58	2.1	443	551	2200	2800	6.3	6.1	22316EW33J
80	170	58	2.1	349	411	2200	2800	6.3	6.2	22316W33M*
85	150	36	2	260	337	3000	3800	2.61	2.6	22217EW33J
85	150	36	2	171	214	2200	2800	2.8	2.7	22217W33M*
85	180	60	3	482	603	2000	2600	7.2	7	22317EW33J
85	180	60	3	377	447	2000	2500	7.4	7.2	22317W33M*
90	160	40	2	308	406	2600	3400	3.4	3.3	22218EW33J
90	160	40	2	209	265	2000	2500	3.6	3.4	22218W33M*
90	160	52.4	2	370	522	1900	2600	4.52	4.4	23218CW33J
90	160	52.4	2	303	412	1900	2400	4.7	4.57	23218W33M*
90	190	64	3	536	673	1900	2400	8.5	8.3	22318EW33J
90	190	64	3	437	522	1900	2400	8.8	8.6	22318W33M*

Notice: Deliveries of bearings marked * need to be negotiated with manufacturer

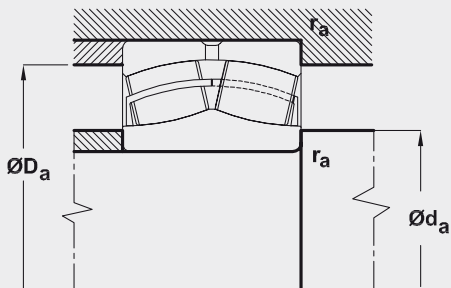

Tapered Bore Bearing Designation	Connecting Dimensions			Adapter Sleeve	Withdrawal Sleeve	Withdrawal Nut	Calculation Coefficients			
	d_a	D_a	r_a				e	Y_1	Y_2	Y_0
	min	max	max							
	mm									
22214EKW33J	77	116	1.5	H314	AH314	KM16	0.23	2.9	4.2	2.8
22314EKW33J	81	138	2	H2314	AH2314X	KM16	0.34	2	3	2
22314KW33M	81	138	2	H2314	AH2314X	KM16	0.37	1.8	2.6	1.7
22215EKW33J	82	121	1.5	H315	AH315	KM17	0.22	3.1	4.5	2.9
22315EKW33J	86	148	2	H2315	AH2315X	KM17	0.33	2	3	2
22315KW33M	86	148	2	H2315	AH2315X	KM17	0.38	1.8	2.5	1.7
22216EKW33J	90	130	2	H316	AH316	KM18	0.22	3.1	4.5	3
22216KW33M	90	130	2	H316	AH316	KM18	0.26	2.6	3.8	2.5
22316EKW33J	91	158	2	H2316	AH2316X	KM18	0.33	2	3	2
22316KW33M	91	158	2	H2316	AH2316X	KM18	0.36	1.8	2.7	1.8
22217EKW33J	95	140	2	H317	AH317X	KM19	0.22	3	4.4	2.9
22217KW33M	95	140	2.5	H317	AH317X	KM19	0.26	2.6	3.7	2.5
22317EKW33J	98	166	2.5	H2317	AH2317X	KM19	0.32	2.1	3.1	2
22317KW33M	98	166	2.5	H2317	AH2317X	KM19	0.36	1.9	2.7	1.8
22218EKW33J	100	150	2	H318	AH318X	KM20	0.23	2.9	4.2	2.8
22218KW33M	100	150	2	H318	AH318X	KM20	0.26	2.6	3.7	2.4
23218CKW33J	100	150	2	H2318	AH3218X	KM20	0.31	2.2	3.3	2.2
23218KW33M	100	150	2	H2318	AH3218X	KM20	0.33	2	3	1.9
22318EKW33J	104	176	2.5	H2318	AH2318X	KM20	0.33	2.1	3.1	2
22318KW33M	104	176	2.5	H2318	AH2318X	KM20	0.37	1.8	2.6	1.7

DOUBLE ROW SPHERICAL ROLLER BEARINGS

d = 95 to 110 mm

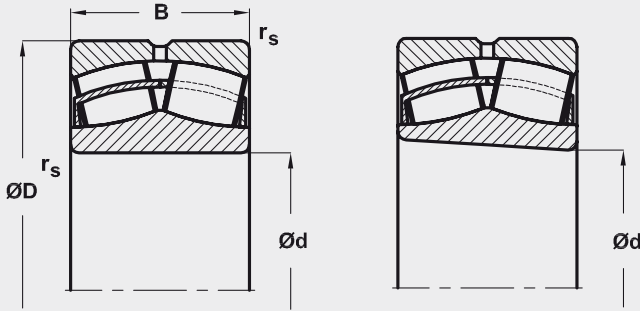

Dimensions				Basic Load Rating		Limiting Speed Frequency for Lubrication		Mass		Cylindrical Bore Bearing Designation
d	D	B	r _s	Dynamic C _r	Static C _{0r}	by Grease	by Oil	Cylindrical Bore	Tapered Bore	
mm				kN		min ⁻¹		kg		
95	170	43	2.1	346	464	2400	3200	4.17	4.1	22219EW33J
95	170	43	2.1	259	329	2000	2500	4.4	4.3	22219W33M*
95	200	67	3	587	744	1800	2300	9.8	9.6	22319EW33J
95	200	67	3	473	566	1800	2200	10.3	10.1	22319W33M*
100	180	46	2.1	379	510	2200	3000	5	4.9	22220EW33J
100	180	46	2.1	290	375	1900	2400	5.3	5.2	22220W33M*
100	180	60.3	2.1	465	667	1700	2200	6.67	6.49	23220CW33J
100	180	60.3	2.1	390	532	1700	2000	6.9	6.7	23220W33M*
100	215	73	3	682	842	1700	2200	12.3	12.1	22320EW33J
100	215	73	3	563	686	1700	2000	13	12.7	22320W33M*
110	170	60	2	402	717	1800	2200	6	5.8	24022CW33J
110	180	56	2	374	585	1900	2600	6	5.32	23122CW33J
110	180	56	2	354	541	1700	2000	6	5.8	23122W33M*
110	180	69	2	501	849	1000	1400	6.9	6.7	24122CW33J
110	200	53	2.1	488	653	2000	2800	7.2	6.94	22222EW33J
110	200	53	2.1	365	474	1700	2000	7.5	7.4	22222W33M*
110	200	69.8	2.1	586	867	1600	2000	9.65	9.38	23222CW33J
110	200	69.8	2.1	502	706	1500	1800	9.9	9.62	23222W33M*
110	240	80	3	805	1000	1500	1900	17.2	16.8	22322EW33J
110	240	80	3	662	801	1500	1800	18.2	17.9	22322W33M*

Notice: Deliveries of bearings marked * need to be negotiated with manufacturer

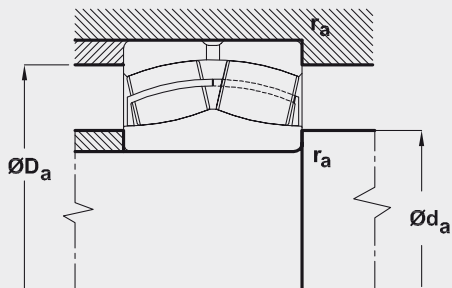

Tapered Bore Bearing Designation	Connecting Dimensions			Adapter Sleeve	Withdrawal Sleeve	Withdrawal Nut	Calculation Coefficients			
	d_a	D_a	r_a				e	Y_1	Y_2	Y_0
	min	max	max							
	mm									
22219EKW33J	107	158	2	H319	AH319X	KM21	0.23	2.9	4.2	2.7
22219KW33M	107	158	2	H319	AH319X	KM21	0.26	2.5	3.6	2.4
22319EKW33J	109	186	2.5	H2319	AH2319	KM21	0.33	2.1	3.1	2
22319KW33M	109	186	2.5	H2319	AH2319	KM21	0.37	1.8	2.6	1.7
22220EKW33J	112	168	2	H320	AH320X	KM22	0.24	2.9	4.1	2.7
22220KW33M	112	168	2	H320	AH320X	KM22	0.27	2.5	3.6	2.4
22320CKW33J	112	168	2	H2320	AH3220X	KM22	0.31	2.2	3.2	2.1
23220KW33M	112	168	2	H2320	AH3220X	KM22	0.34	2	2.8	1.9
22320EKW33J	114	201	2.5	H 2320	AH 2320X	KM 22	0.33	2.0	3.0	2.0
22320KW33M	113	201	2.5	H2320	AH2320X	KM22	0.37	1.8	2.6	1.7
24022CK30W33J	120	170	2	--	--	--	0.32	2.1	3.2	2.1
23122CKW33J	120	170	2	H3122	AH3122X	KM24	0.3	2.3	3.4	2.2
23122KW33M	120	170	2	H3122	AH3122X	KM24	0.31	2.2	3.1	2.1
24122CK30W33J	120	170	2	--	AH24122	KM23	0.35	1.9	2.8	1.9
22222EKW33J	122	188	2	H3222	AH3120X	KM24	0.25	2.7	4	2.6
22222KW33M	122	188	2	H3222	AH3120X	KM24	0.27	2.4	3.5	2.3
23222CKW33J	122	188	2	H2322	AH3222X	KM25	0.33	2.1	3.1	2
23222KW33M	122	188	2	H2322	AH3222X	KM25	0.36	1.9	2.7	1.8
22322EKW33j	124	226	2.5	H2322	AH2322X	KM25	0.33	2.1	3.1	2
22322KW33M	124	226	2.5	H2322	AH2322X	KM25	0.36	1.8	2.6	1.7

DOUBLE ROW SPHERICAL ROLLER BEARINGS

d = 120 to 140 mm

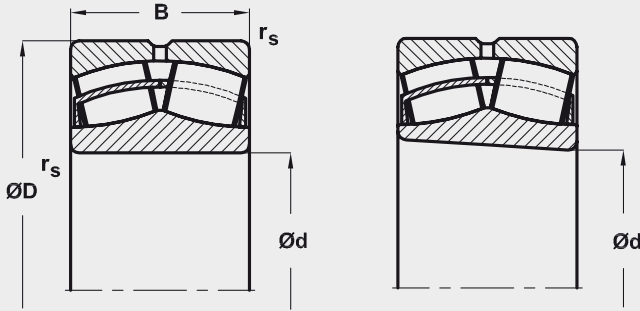

Dimensions				Basic Load Rating		Limiting Speed Frequency for Lubrication		Mass		Cylindrical Bore Bearing Designation
d	D	B	r _s	C _r	C _{0r}	by Grease	by Oil	Cylindrical Bore	Tapered Bore	
mm				kN		min ⁻¹		kg		
120	180	46	2	346	572	2000	2800	4.1	3.97	23024CW33J
120	180	46	2	287	467	1600	1900	4.3	4.2	23024W33M*
120	180	60	2	413	770	1600	2000	5.5	5.4	24024CW33J
120	200	62	2	430	648	1500	1800	8.2	8	23124W33M
120	200	80	2	639	1080	950	1300	10.2	10.0	24124CW33J
120	215	58	2.1	553	775	1900	2600	9	8.8	22224EW33J
120	215	58	2.1	439	580	1600	1900	9.4	9.2	22224W33M*
120	215	76	2.1	678	1020	1500	1900	11.8	11.5	23224CW33J
120	215	76	2.1	564	803	1400	1700	12.3	11.9	23224W33M*
120	260	86	3	938	1180	1400	1800	21.5	21.1	22324EW33J
120	260	86	3	782	962	1400	1700	22.1	21.6	22324W33M*
130	200	52	2	444	711	1900	2600	5.94	5.76	23026CW33J
130	200	52	2	367	579	1500	1800	6.3	6.12	23026W33M*
130	200	69	2	539	978	1500	1900	8	7.9	24026CW33J
130	210	64	2	474	752	1400	1700	9.1	8.82	23126W33M
130	210	80	2	657	1160	900	1200	10.9	10.7	24126CW33J
130	230	64	3	641	948	1800	2400	11.2	11	22226EW33J
130	230	64	3	525	726	1500	1800	11.8	11.7	22226W33M*
130	230	80	3	753	1180	1300	1700	13.9	13.5	23226CW33J
130	230	80	3	636	948	1300	1600	15	14.4	23226W33M*
130	280	93	4	1090	1380	1500	1900	26.8	26.2	22326EW33J
130	280	93	4	904	1130	1300	1600	28.6	28	22326W33M*
140	210	53	2	463	781	1800	2400	6.45	6.25	23028CW33J
140	210	53	2	380	633	1400	1700	6.87	6.66	23028W33M*
140	210	69	2	549	1040	1400	1800	8.6	8.4	24028CW33J
140	225	68	2.1	540	865	1300	1600	10.8	10.5	23128W33M
140	225	85	2.1	740	1330	850	1100	13.2	13.0	24128CW33J
140	250	68	3	747	1080	1700	2200	14.1	13.8	22228EW33J

Notice: Deliveries of bearings marked * need to be negotiated with manufacturer

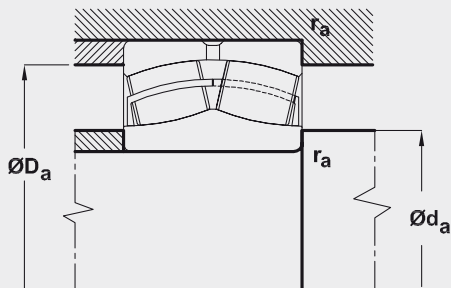

Tapered Bore Bearing Designation	Connecting Dimensions			Adapter Sleeve	Withdrawal Sleeve	Withdrawal Nut	Calculation Coefficients			
	d_a	D_a	r_a				e	Y_1	Y_2	Y_0
	min	max	max							
	mm									
23024CKW33J	128	171	2	H3024	AH3024X	KM26	0.23	3	4.5	2.9
23024KW33M	128	171	2	H3024	AH3024X	KM26	0.24	2.7	3.9	2.6
24024CK30W33J	128	171	2	--	AH24024	KM25	0.3	2.3	3.4	2.2
23124KW33M	130	190	2	H3124	AH3124X	KM26	0.31	2.1	3.1	2
24124CK30W33J	131	189	2	-	AH 24124	KM 26	0.37	1.8	2.7	1.8
22224EKW33J	132	203	2	H3124	AH3124X	KM26	0.25	2.7	3.9	2.5
22224KW33M	132	203	2	H3124	AH3124X	KM26	0.28	2.4	3.4	2.3
23224CKW33J	132	203	2	H2324	AH3224X	KM27	0.33	2	3	2
23224KW33M	132	203	2	H2324	AH3224X	KM27	0.36	1.9	2.7	1.8
22324EKW33J	132	203	2.5	H2324	AH2324X	KM27	0.33	2.1	3.1	2
22324KW33M	134	246	2.5	H2324	AH2324X	KM27	0.36	1.9	2.7	1.8
23026CKW33J	138	191	2	H3026	AH3026X	KM28	0.23	2.9	4.3	2.9
23026KW33M	138	191	2	H3026	AH3026X	KM28	0.26	2.6	3.8	2.5
24026CK30W33J	138	191	2	--	AH24026	KM27	0.31	2.2	3.2	2.1
23126KW33M	140	200	2	H3126	AH3126X	KM28	0.3	2.2	3.2	2.1
24126CK30W33J	141	199	2	-	AH 24126	KM 28	0.35	1.9	2.9	1.9
22226EKW33J	144	216	2.5	H3126	AH3126X	KM28	0.26	2.6	3.8	2.5
22226KW33M	144	216	2.5	H3126	AH3126X	KM28	0.29	2.3	3.3	2.2
23226CKW33J	144	216	2.5	H2326	AH3226X	KM29	0.33	2.1	3.1	2
23226KW33M	144	216	2.5	H2326	AH3226X	KM29	0.35	1.9	2.7	1.8
22326EKW33J	148	262	3	H2326	AH2326X	KM29	0.33	2.1	3.1	2
22326KW33M	148	262	3	H2326	AH2326X	KM29	0.36	1.8	2.7	1.8
23028CKW33J	148	200	2	H3028	AH3028X	KM30	0.22	3	4.5	3
23028KW33M	148	200	2	H3028	AH3028X	KM30	0.24	2.7	3.9	2.6
24028CK30W33J	148	200	2	--	AH24028	KM29	0.29	2.3	3.4	2.3
23128KW33M	152	213	2	H3128	AH3128X	KM30	0.3	2.2	3.2	2.1
24128CK30W33J	152	213	2	-	AH 24128	KM 30	0.35	1.9	2.9	1.9
22228EKW33J	154	236	2.5	H3128	AH3128X	KM30	0.25	2.7	3.9	2.5

DOUBLE ROW SPHERICAL ROLLER BEARINGS

d = 140 to 170 mm

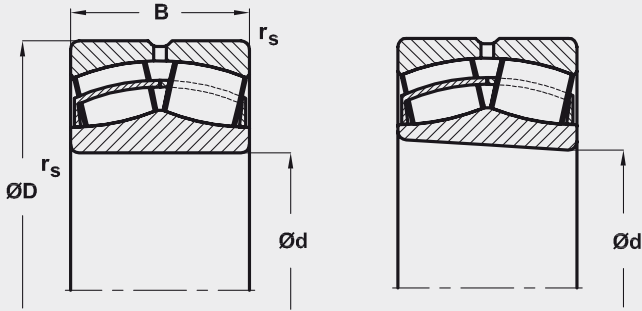

Dimensions				Basic Load Rating		Limiting Speed Frequency for Lubrication		Mass		Cylindrical Bore Bearing Designation
d	D	B	r _s	C _r	C _{0r}	by Grease	by Oil	Cylindrical Bore	Tapered Bore	
mm				kN		min ⁻¹		kg		
140	250	68	3	605	822	1400	1700	15	14.6	22228W33M*
140	250	88	3	815	1320	1200	1600	18.6	18	23228CW33M
140	300	102	4	993	1270	1200	1500	35.6	34.8	22328W33M
150	225	56	2.1	517	881	1700	2200	7.86	7.62	23030CW33J
150	225	56	2.1	419	697	1300	1600	8.25	8.01	23030W33M*
150	225	75	2.1	635	1220	1300	1700	10.7	10.5	24030CW33J
150	250	80	2.1	711	1130	1200	1500	16.6	16.1	23130W33M
150	250	100	2.1	968	1690	800	1000	19.9	19.6	24130CW33J
150	270	73	3	863	1260	1600	2000	17.9	17.5	22230EW33J
150	270	73	3	668	920	1300	1600	18.6	18.2	22230W33M*
150	270	96	3	874	1300	1100	1400	24.6	23.9	23230W33M
150	320	108	4	1100	1480	1100	1400	42.5	42.3	22330W33M
160	240	60	2.1	496	848	1200	1500	10.3	10	23032W33M
160	240	60	2.1	587	1010	1700	2200	9.4	9.1	23032CW33J
160	240	80	2.1	719	1400	1100	1500	12.9	12.7	24032CW33J
160	270	86	2.1	784	1240	1100	1400	21.3	20.7	23132W33M
160	270	109	2.1	1120	1980	700	900	25.7	25.3	24132CW33J
160	290	80	3	978	1440	1500	1900	22.7	22.2	22232EW33J
160	290	80	3	978	1442	1650	2090	22.7	22.2	22232EW33JTN
160	290	80	3	814	1140	1200	1500	24.4	23.9	22232W33M*
160	290	104	3	1140	1860	1200	1600	31	30.14	23232CW33M*
160	340	114	4	1250	1680	1000	1300	51.9	50.8	22332W33M
170	260	67	2.1	618	1050	1100	1400	13.8	13.4	23034W33M
170	260	90	2.1	875	1660	1000	1400	17.4	17.2	24034CW33J
170	280	88	2.1	826	1350	1000	1300	22.8	22.2	23134W33M
170	280	109	2.1	1150	2090	670	850	27.0	26.6	24134CW33J
170	310	86	2.4	921	1310	1100	1400	30	29.4	22234W33M
170	310	110	4	1280	1880	1100	1400	37.7	36.4	23234CW33M
170	360	120	4	1400	1970	940	1200	59.2	58.2	22334W33M

Notice: Deliveries of bearings marked * need to be negotiated with manufacturer

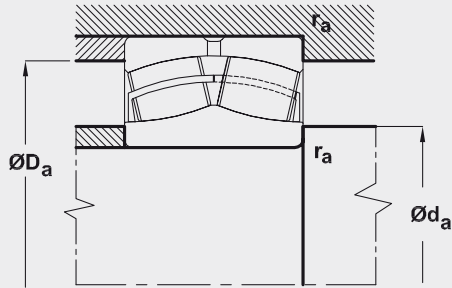

Tapered Bore Bearing Designation	Connecting Dimensions			Adapter Sleeve	Withdrawal Sleeve	Withdrawal Nut	Calculation Coefficients			
	d _a	D _a	r _a				e	Y ₁	Y ₂	Y ₀
	min	max	max							
	mm									
22228KW33M	154	236	2.5	H3128	AH3128X	KM30	0.28	2.4	3.4	2.2
23228CKW33M	154	236	2.5	H2328	AH3228X	KM31	0.33	2	3	2
22328KW33M	158	282	3	H2328	AH2328X	KM31	0.38	1.8	2.5	1.7
23030CKW33J	159	213	2	H3030	AH3030X	KM32	0.22	3.1	4.6	3
23030KW33M	159	213	2	H3030	AH3030X	KM32	0.24	2.7	3.9	2.6
24030CK30W33J	159	213	2	--	AH24030	KM31	0.3	2.3	3.4	2.2
23130KW33M	162	238	2	H3130	AH3130X	KM33	0.32	2.1	3	2
24130CK30W33J	162	238	2	-	AH 24130	KM 32	0.37	1.8	2.7	1.8
22230EKW33J	164	256	2.5	H3130	AH3130X	KM33	0.25	2.7	3.9	2.5
22230KW33M	164	256	2.5	H3130	AH3130X	KM33	0.28	2.3	3.4	2.2
23230KW33M	164	256	2.5	H2330	AH3230X	KM33	0.36	1.8	2.7	1.8
22330KW33M	168	302	3	H2330	AH2330X	KM33	0.38	1.8	2.6	1.7
23032KW33M	169	228	2	H3032	AH3032	KM34	0.24	2.8	4	2.6
23032CKW33J	171	229	2	H3032	AH3032	KM34	0.22	3.1	4.6	3
24032CK30W33J	171	229	2	-	AH 24032	KM 34	0.30	2.3	3.4	2.2
23132KW33M	172	258	2	H3132	AH3132	KM36	0.32	2.1	3	2
24132CK30W33J	172	258	2	-	AH 24132	KM 34	0.38	1.8	2.7	1.8
22232EKW33J	174	276	2.5	H3132	AH3132	KM36	0.26	2.6	3.8	2.5
22232EKW33JTN	174	276	2.5	H3132	AH3132	KM36	0.26	2.6	3.8	2.5
22232KW33M	174	276	2.5	H3132	AH3132	KM36	0.29	2.3	3.3	2.2
23232CKW33M	174	276	2.5	H2332	AH3232	KM36	0.36	1.9	2.8	1.8
22332KW33M	178	322	3	H2332	AH2332	KM36	0.37	1.8	2.6	1.7
23034KW33M	179	248	2	H3034	AH3034	KM36	0.25	2.7	3.9	2.6
24034CK30W33J	181	249	2	-	AH 24034	KM 36	0.31	2.2	3.2	2.1
23134KW33M	182	268	2	H3134	AH3134	KM38	0.31	2.1	3.1	2
24134CK30W33J	182	268	2	-	AH 24134	KM 36	0.36	1.9	2.8	1.8
22234KW33M	188	293	3	H3134	AH3134	KM38	0.29	2.3	3.3	2.1
23234CKW33M	188	293	3	H2334	AH3234	KM38	0.36	1.9	2.8	1.8
22334KW33M	188	342	3	H2334	AH2334	KM38	0.37	1.8	2.6	1.7

DOUBLE ROW SPHERICAL ROLLER BEARINGS

d = 180 to 220 mm

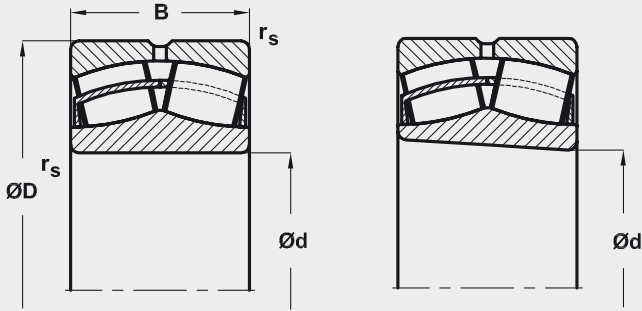

Dimensions				Basic Load Rating		Limiting Speed Frequency for Lubrication		Mass		Cylindrical Bore Bearing Designation
d	D	B	r _s	C _r	C _{0r}	by Grease	by Oil	Cylindrical Bore	Tapered Bore	
mm				kN		min ⁻¹		kg		
180	280	74	2.1	725	1230	1000	1300	17.6	17.1	23036W33M
180	280	100	2.1	1050	1980	950	1300	22.9	22.6	24036CW33J
180	300	96	3	957	1540	940	1200	28.9	28	23136W33M
180	300	118	3	1250	2400	700	850	32.9	32.4	24136CW33J
180	320	86	4	943	1380	1000	1300	31.5	30.8	22236W33M
180	320	112	4	1360	2110	1000	1300	39.8	38.6	23236CW33M
180	380	126	4	1540	2130	890	1100	73.2	71.7	22336W33M
190	290	75	2.1	759	1310	940	1200	18.8	18.3	23038W33M
190	320	104	3	1130	1840	890	1100	36.1	35	23138W33M
190	340	92	4	1040	1550	940	1200	38.4	37.7	22238W33M
190	340	120	4	1550	2420	1000	1260	47.65	47.1	23238CW33M
190	400	132	5	1920	2710	840	1000	84.1	82.9	22338CW33M
200	310	82	2.1	880	1800	890	1100	23.8	23.4	23040CW33M
200	310	109	2.1	1250	2370	900	1200	30.8	30.3	24040EW33MH
200	340	112	3	1240	2010	840	1000	44	42.7	23140W33M
200	340	140	3	1730	3160	560	700	53.4	52.6	24140EW33MH
200	360	98	4	1164	1760	890	1100	46	45.1	22240W33M
200	360	128	4	1710	2760	940	1200	58.6	56.7	23240CW33M
200	420	138	5	1820	2650	790	940	99	97	22340W33M
220	340	90	3	1020	2120	790	940	26.6	25.7	23044CW33M
220	340	118	3	1480	2830	850	1100	39.7	39	24044EW33MH
220	370	120	4	1480	2470	750	890	56.8	55.2	23144W33M
220	370	150	4	1990	3690	500	630	67.1	66.1	24144EW33MH
220	400	108	4	1380	2080	790	940	63	61	22244W33M
220	400	144	4	2040	3750	710	840	83	79	23244CW33M
220	460	145	5	2110	3130	750	890	125	122	22344W33M

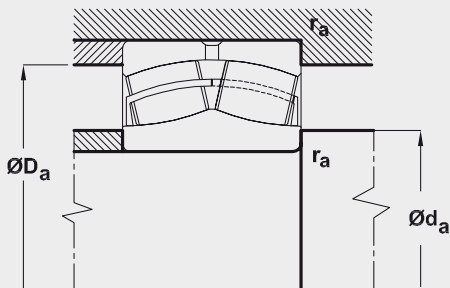

Tapered Bore Bearing Designation	Connecting Dimensions			Adapter Sleeve	Withdrawal Sleeve	Withdrawal Nut	Calculation Coefficients			
	d_a	D_a	r_a				e	Y_1	Y_2	Y_0
	min	max	max							
	mm									
23036KW33M	189	268	2	H3036	AH3036	KM38	0.26	2.6	3.7	2.5
24036CK30W33J	191	269	2	-	AH24036	KM38	0.32	2.1	3.1	2.0
23136KW33M	194	286	2.5	H3136	AH3136	KM40	0.32	2.1	3	2
24136CK30W33J	194	286	2.5	-	AH24136	KM38	0.37	1.8	2.7	1.8
22236KW33M	198	302	3	H3136	AH2236	KM40	0.28	2.4	3.4	2.3
23236CKW33M	198	302	3	H2336	AH3236	KM40	0.36	1.9	2.8	1.9
22336KW33M	198	362	3	H2336	AH2336	KM40	0.37	1.8	2.6	1.7
23038KW33M	202	278	2	H3038	AH3038	HML41T	0.25	2.7	3.8	2.5
23138KW33M	204	306	2.5	H3138	AH3138	HM42T	0.32	2.1	3	2
22238KW33M	208	322	3	H3138	AH2238	HM42T	0.29	2.3	3.4	2.2
23238CKW33M	208	322	3	H2338	AH3238	HM42T	0.36	1.9	2.8	1.9
22338CKW33M	212	378	4	H2338	AH2338	HM42T	0.36	1.9	2.8	1.9
23040CKW33M	212	298	2	H3040	AH3040	HML43T	0.25	2.7	4	2.7
24040EK30W33MH	212	298	2	-	AOH24040	HM42	0.32	2.1	3.1	2.1
23140KW33M	214	326	2.5	H3140	AH3140	HM44T	0.33	2	2.9	1.9
24140EK30W33MH	214	326	2.5	-	AOH24140	HM42	0.39	1.9	2.6	1.7
22240KW33M	218	342	3	H3140	AH2240	HM44T	0.29	2.3	3.3	2.2
23240CKW33M	218	342	3	H2340	AH3240	HM44T	0.36	1.9	2.8	1.8
22340KW33M	222	398	4	H2340	AH2340	HM44T	0.36	1.9	2.7	1.8
23044CKW33M	234	326	2.5	H3044	AH3044	HML47T	0.25	2.7	4	2.7
24044EK30W33MH	234	326	2.5	-	AOH24044	HM46	0.32	2.3	3.1	2.1
23144KW33M	238	352	3	H3144	AH3144	HM48T	0.32	2	3	2
24144EK30W33MH	238	352	3	-	AOH24144	HM46	0.38	1.8	2.6	1.7
22244KW33M	238	382	3	H3144	AH2244	HM48T	0.28	2.4	3.4	2.2
23244CKW33M	238	382	3	H2344	AH3244	HM48T	0.37	1.9	2.6	1.7
22344KW33M	242	438	4	H2344	AH2344	HM48T	0.35	1.9	2.8	1.8

DOUBLE ROW SPHERICAL ROLLER BEARINGS

d = 240 to 320 mm

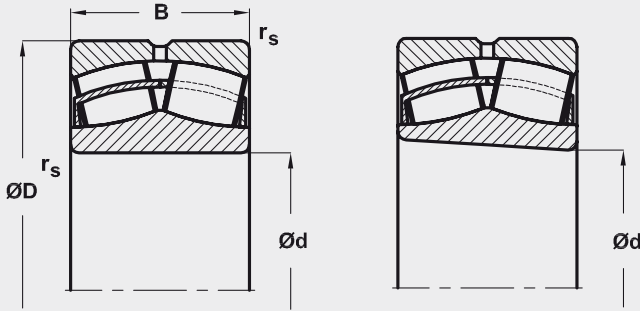

Dimensions				Basic Load Rating		Limiting Speed Frequency for Lubrication		Mass		Cylindrical Bore Bearing Designation
d	D	B	rs	Dynamic Cr	Static Cor	by Grease	by Oil	Cylindrical Bore	Tapered Bore	
mm				kN		min ⁻¹		kg		
240	360	92	3	1080	2320	750	890	34.9	33.8	23048CW33M
240	400	128	4	1690	2860	710	840	68.7	66.7	23148W33M
240	400	160	4	2280	4260	480	600	82.5	81.3	24148EW33MH
240	440	120	4	1660	2560	750	890	85	83.2	22248W33M
240	440	160	4	2530	4300	670	850	113	110	23248CW33M
240	500	155	5	2440	3690	670	790	159	156	22348W33M
260	400	104	4	1460	2700	670	790	46.8	45.3	23052CW33M
260	440	144	4	2240	3720	670	790	90.5	87.8	23152CW33M
260	440	180	4	2790	5320	430	530	115	113	24152EW33MH
260	480	130	5	1940	3030	670	790	111	109	22252W33M
260	480	174	5	2700	4430	600	710	147	142	23252W33M
260	540	165	6	2760	4220	600	710	196	192	22352W33M
280	420	106	4	1440	2690	630	750	54.5	52.9	23056W33M
280	460	146	5	2180	3900	600	710	102.8	99	23156W33M
280	460	180	5	2880	5360	400	500	121	119	24156EW33MH
280	500	130	5	2010	3200	630	750	119	116	22256W33M
280	500	176	5	2850	4770	560	670	157	152	23256W33M
280	580	175	6	3300	5600	600	750	232	227	22356CW33M
300	460	118	4	1780	3240	560	670	75.8	73.6	23060W33M
300	500	160	5	2560	4490	530	630	133.6	129.5	23160W33M
300	500	200	5	3420	6790	360	450	163	160	24160EW33MH
300	540	140	5	2350	3810	560	670	150	147	22260W33M
300	540	192	5	3350	5570	500	600	200	195	23260W33M
320	480	121	4	1890	3510	530	630	81.2	78.8	23064W33M
320	540	176	5	3020	5390	500	600	175.3	170.1	23164W33M
320	540	218	5	4020	7870	340	430	208	205	24164EW33MH
320	580	150	5	2700	4430	530	630	187	181	22264W33M
320	580	208	5	3880	6520	450	530	253	246	23264W33M

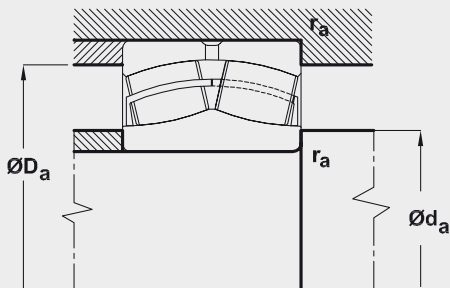

Tapered Bore Bearing Designation	Connecting Dimensions			Adapter Sleeve	Withdrawal Sleeve	Withdrawal Nut	Calculation Coefficients			
	d_a	D_a	r_a				e	Y_1	Y_2	Y_0
	min	max	max							
	mm									
23048CKW33M	254	346	2.5	H3048	AH3048	HML52T	0.24	2.8	4.2	2.8
23148KW33M	258	382	3	H3148	AH3148	HM52T	0.32	2.1	3	2
24148EK30W33MH	258	422	3		AOH24148	HM50	0.38	1.8	2.7	1.8
22248KW33M	258	422	3	H3148	AH2248	HM52T	0.29	2.3	3.3	2.2
23248CKW33M	258	422	3	H2348	AH2348	HM52T	0.35	1.9	2.9	1.8
22348KW33M	262	478	4	H2348	AH2348	HM52T	0.34	2	2.9	1.9
23052CKW33M	278	382	3	H3052	AH3052	HML56T	0.25	2.7	4	2.7
23152CKW33M	278	422	3	H3152	AH3152	HM58T	0.32	2	3.1	2
24152EK30W33MH	278	422	3		AOH24152	HM54	0.32	2	3.1	2
22252KW33M	282	458	4	H3152	AH2252	HM58T	0.29	2.3	3.4	2.2
23252KW33M	282	458	4	H2352	AH2352	HM58T	0.37	1.8	2.6	1.7
22352KW33M	288	512	5	H2352	AH2352	HM58T	0.34	2	2.9	1.9
23056KW33M	298	402	3	H3056	AH3056	HML60T	0.24	2.7	4	2.6
23156KW33M	302	438	4	H3156	AH3156	HM62T	0.31	2.1	3	2
24156EK30W33MH	300	440	4				0.37	1.8	2.7	1.8
22256KW33M	302	478	4	H3156	AH2256	HM62T	0.28	2.4	3.5	2.3
23256KW33M	302	478	4	H2356	AH2356	HM62T	0.36	1.9	2.7	1.8
22356CKW33M	308	522	5	H2356	AH2356	HM62T	0.31	2.2	3.2	2.1
23060KW33M	318	442	3	H3060	AH3060	HML64T	0.25	2.7	3.8	2.5
23160KW33M	322	478	4	H3160	AH3160	HM66T	0.32	2.1	3	2
24160EK30W33MH	320	480	4				0.37	1.8	2.7	1.8
22260KW33M	322	518	4	H3160	AH2260	HM66T	0.27	2.5	3.6	2.4
23260KW33M	322	518	4	H3260	AH3260	HM66T	0.36	1.8	2.7	1.8
23064KW33M	338	462	3	H3064	AH3064	HML69T	0.24	2.7	3.9	2.6
23164KW33M	342	518	4	H3164	AH3164	HM70T	0.32	2	3	2
24164EK30W33MH	342	518	4				0.38	1.8	2.6	1.7
22264KW33M	342	558	4	H3164	AH2264	HM70T	0.27	2.5	3.6	2.3
23264KW33M	342	558	4	H3264	AH3264	HM70T	0.37	1.8	2.6	1.7

DOUBLE ROW SPHERICAL ROLLER BEARINGS

d = 340 to 460 mm

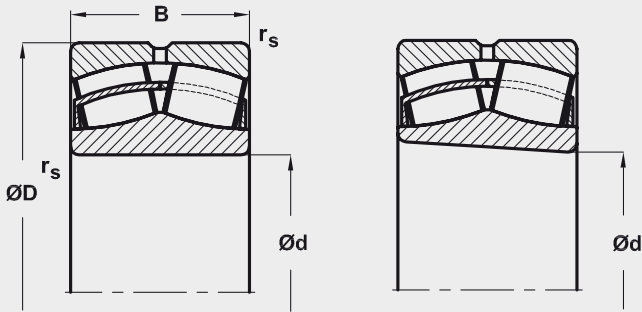

Dimensions				Basic Load Rating		Limiting Speed Frequency for Lubrication		Mass		Cylindrical Bore Bearing Designation
d	D	B	r _s	C _r	C _{0r}	by Grease	by Oil	Cylindrical Bore	Tapered Bore	
mm				kN		min ⁻¹		kg		
340	520	133	5	2270	4210	500	600	108	105	23068W33M
340	520	180	5	3200	6710	530	670	141	139	24068EW33MH
340	580	190	5	3450	6100	450	530	208.6	202.2	23168W33M
340	620	224	6	4430	7560	420	500	313	304	23268W33M
360	540	134	5	2360	4460	450	530	114	111	23072W33M
360	600	192	5	3630	6550	420	500	231.6	223.8	23172W33M
360	650	232	6	4780	8550	400	500	342	332	23272CW33M
380	560	135	5	2410	4700	420	500	120	116.5	23076W33M
380	560	180	5	3330	7420	480	600	154	152	24076EW33MH
380	620	194	5	3740	6970	400	470	244.4	236.5	23176W33M
380	680	240	6	5160	8920	380	480	394	382	23276W33M
400	600	148	5	2860	5500	400	470	156	152	23080W33M
400	650	200	6	4040	7580	380	450	273	265	23180W33M
400	650	250	6	5410	11150	180	240	334	329	24180EW33MH
400	720	256	6	5800	10120	350	420	476	463	23280W33M
400	820	243	7.5	6350	10190	400	500	628.7	612	22380CW33M
420	620	150	5	2950	5850	380	450	164	159	23084W33M
420	700	224	6	5030	10800	360	450	362.5	348	23184CW33M
420	700	280	6	6440	13480	170	220	445	438	24184EW33MH
420	760	272	6	6400	11300	320	400	535	520	23284CW33M
440	650	157	6	3210	6410	350	420	188	182	23088W33M
440	720	226	6	4480	9350	330	400	390.2	378.7	23188W33M
440	790	280	7.5	6820	12030	320	380	613	595	23288W33M
460	680	163	6	3480	7000	330	400	213.7	207.3	23092W33M
460	760	240	7.5	5720	10950	320	380	456	441	23192W33M
460	760	300	7.5	7370	15530	160	200	556	547	24192EW33MH

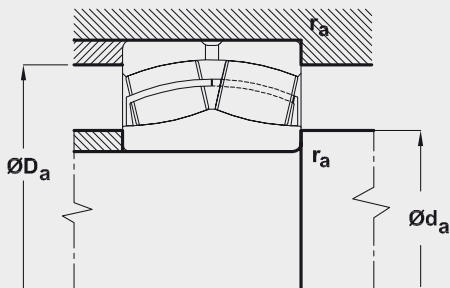

Tapered Bore Bearing Designation	Connecting Dimensions			Adapter Sleeve	Withdrawal Sleeve	Withdrawal Nut	Calculation Coefficients			
	d_a	D_a	r_a				e	Y_1	Y_2	Y_0
	min	max	max							
	mm									
23068KW33M	362	498	4	H3068	AH3068	HML73T	0.25	2.7	3.9	2.6
24068EKW33MH	358	502	4	--	AH24068-H	HM3072	0.33	2	3	2
23168KW33M	362	558	4	H3168	AH3168	HM74T	0.33	2	2.9	1.9
23268KW33M	368	592	5	H3268	AH3268	HM74T	0.37	1.8	2.6	1.7
23072KW33M	382	518	4	H3072	AH3072	HML77T	0.24	2.8	4	2.6
23172KW33M	382	578	4	H3172	AH3172	HM80T	0.32	2	3	2
23272CKW33M	386	622	5	H3272	AH3272G	HM3076	0.35	1.9	2.9	1.8
23076KW33M	402	538	4	H3076	AH3076	HML82T	0.23	2.9	4.2	2.7
24076EK30W33MH	398	542	4	-	AOH24076	HM3080	0.29	2.3	3.5	2.3
23176KW33M	402	598	4	H3176	AH3176	HM84T	0.31	2.2	3.1	2.1
23276KW33M	408	652	5	H3276	AH3276	HM84T	0.36	1.9	2.7	1.8
23080KW33M	422	578	5	H3080	AH3080	HML86T	0.24	2.8	4	2.7
23180KW33M	428	622	5	H3180	AH3180	HM88T	0.3	2.2	3.2	2.1
24180EK30W33MH	428	622	5	--	AH24180	HM3184	0.35	1.9	2.8	1.9
23280KW33M	428	692	5	H3280	AH3280	HM88T	0.36	1.8	2.7	1.8
22380CKW33M	436	786	6	--	--	--	0.3	2.2	3.3	2.2
23084KW33M	442	598	4	H3084	AH3084	HML90T	0.23	2.9	4.1	2.7
23184CKW33M	448	672	5	H3184	AH3184	HM92T	0.32	2.1	3.2	2
24184EK30W33MH	446	674	5	-	AOH 24184	HM 3188	0.37	1.8	2.7	1.8
23284CKW33M	456	724	6	H3284	AH3284	HM92T	0.36	1.7	2.7	1.8
23088KW33M	468	622	5	H3088	AH3088X	HML94T	0.23	2.9	4.1	2.7
23188KW33M	468	692	5	H3188	AH3188X	HM96T	0.32	2.1	3	2
23288KW33M	476	754	6	H3288	AH3288X	HM96T	0.36	1.8	2.7	1.8
23092KW33M	488	652	5	H3092	AH3092X	HML98T	0.23	2.9	4.2	2.8
23192KW33M	496	724	6	H3192	AH3192X	HM102T	0.31	2.1	3.1	2
24192EK30W33MH	492	728	6				0.37	1.8	2.7	1.8

DOUBLE ROW SPHERICAL ROLLER BEARINGS

d = 480 to 850 mm

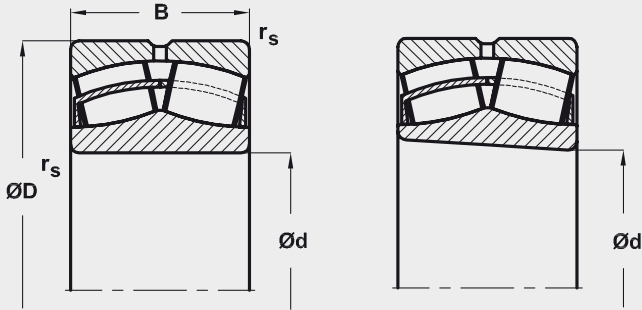

Dimensions				Basic Load Rating		Limiting Speed Frequency for Lubrication		Mass		Cylindrical Bore Bearing Designation
d	D	B	r _s	Dynamic C _r	Static C _{0r}	by Grease	by Oil	Cylindrical Bore	Tapered Bore	
mm				kN		min ⁻¹		kg		
480	700	165	6	3400	6950	320	380	230	223	23096W33M
480	790	248	7.5	6120	11770	300	350	485	469	23196W33M
500	720	167	6	3760	7780	300	350	236	228	230/500W33M
500	830	264	7.5	6740	12890	280	330	570	550	231/500W33M
530	780	185	6	4440	9240	280	330	322.9	313.5	230/530W33M
560	820	195	6	5110	12050	320	400	356.7	346	230/560CW33M
600	870	200	6	5500	12900	260	300	405	400	230/600CW33M
630	920	212	7.5	6270	13360	240	300	485	470	230/630W33M
670	980	230	7.5	6820	14690	200	280	715	698	230/670W33M
750	1360	475	7.5	19600	44000	150	190	3070	2990	232/750CW33M
800	1150	258	7.5	8620	19650	180	220	939	911	230/800W33M
850	1220	272	7.5	9610	22080	160	200	1110	1080	230/850W33M

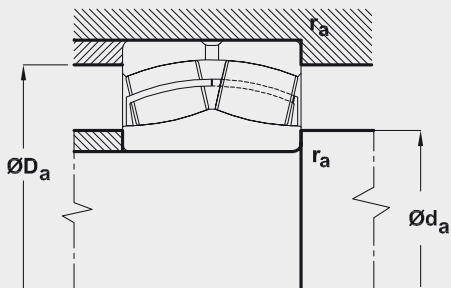

Tapered Bore Bearing Designation	Connecting Dimensions			Adapter Sleeve	Withdrawal Sleeve	Withdrawal Nut	Calculation Coefficients			
	d_a	D_a	r_a				e	Y_1	Y_2	Y_0
	min	max	max							
	mm									
23096KW33M	508	672	5	H3096	AH3096X	HML104T	0.23	2.9	4.4	2.9
23196KW33M	516	754	6	H3196	AH3196X	HM106T	0.31	2.2	3.1	2.1
230/500KW33M	528	692	5	H30/500	AH30/500X	HML108T	0.22	3	4.3	2.9
231/500KW33M	536	794	6	H31/500	AH31/500X	HM110T	0.31	2.1	3	2
230/530KW33M	558	752	5	H30/530	AH30/530	HML112T	0.22	3	4.3	2.9
230/560CKW33M	588	792	5	H30/560	AH30/560	HML118T	0.22	3.1	4.6	3
230/600CKW33M	633	838	5	H30/600	AH30/600	HM30/630	0.22	2.9	4.2	2.8
230/630KW33M	666	884	6	H30/630	AH30/630	HM30/670	0.21	3.1	4.5	2.9
230/670KW33M	706	944	6	H30/670	AH30/670	HM30/710	0.23	3	4.4	2.9
232/750CKW33M	860	1200	6	H32/750	AH32/750	HM31/800	0.31	1.9	3.6	2.4
230/800KW33M	836	1114	6	H30/800	AH30/800	HM30/850	0.21	3.1	4.5	3
230/850KW33M	886	1184	6	--	AH30/850	HM30/900	0.21	3.1	4.5	3

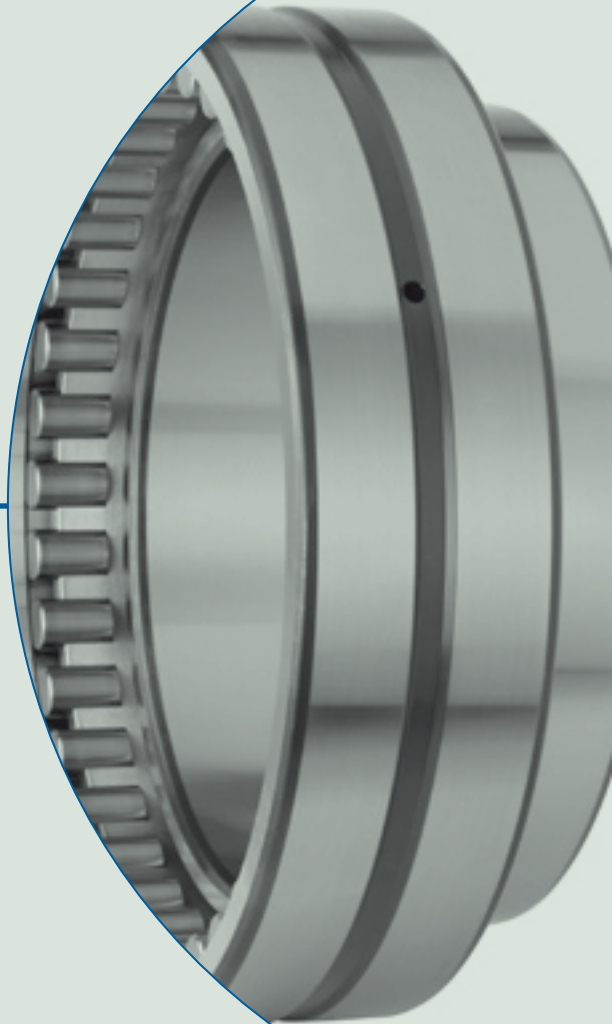

DOUBLE ROW CYLINDRICAL ROLLER BEARINGS

DOUBLE ROW ROLLER BEARINGS

Double Row Roller Bearings NNU49.. are separable, thus enabling their easy mounting and dismantling in bedding. Both bearing rings are always fitted with offset. They are primarily designed for rolling mountings of machine tools spindles and enable applications in transfer of higher radial loads and high precision run. They are fitted with two rows of cylinders centered in outer rings raceways. The inner ring is plain, allowing axial displacement at bearing operation in mounting. The bearing is provided with single-piece brass prong-type cage guided on rolling elements.

- The supporting surfaces of double row cylindrical roller bearings must not be misaligned.
- Precision execution of double row cylindrical roller bearings permits to reach high speed frequencies.
- Bearing outer rings are provided with peripheral groove with three lubricating holes for easy lubrication (supplementary suffix S).
- The inner design of bearings is an outcome of development knowledge utilization and is optimized for ideal stress distribution in maximum length of rolling contact, with elimination of its concentration on peripheral parts.
- Bearings are manufactured and supplied in tolerance classes P6, P5 and P4 and in radial internal clearances below standard C1NA, C2, in standard radial internal clearance CN and in clearances higher than standard C3, C4 and C5. Further they are available also in narrower range of radial internal clearances C4H, C3M and C2L.
- The measurements of boundary dimensions and mounting radius conform to specifications of ISO 15 and ISO 355 standards.
- Bearing rings and cylinders in order of size are manufactured from bearing steel 100Cr6, 100CrMnMo7 stabilized for operation up to + 150 °C, optionally for higher operating temperatures (up to + 200 °C – designation S1, up to + 250 °C – designation S2, up to + 300 °C – designation S3).
- Basic dynamic load rating of bearings C_r is calculated according to ISO 281, basic static load rating of bearings C_{or} is calculated according to ISO 76.

Designation Scheme

NNU4920SMP53

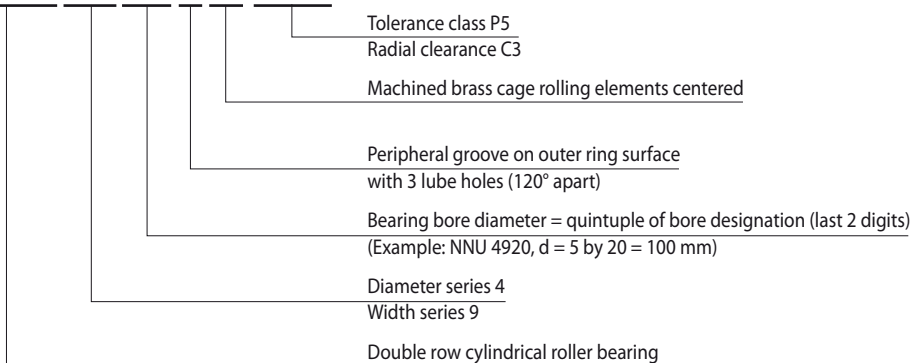

DOUBLE ROW ROLLER BEARINGS

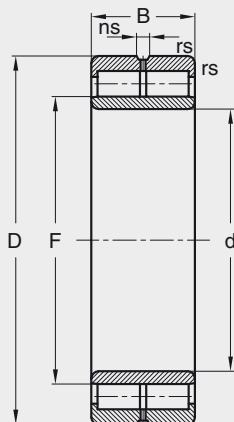

Hřídél Shaft Árbol	Označení ložiska Bearing Designation Denominación del rodamiento	Hlavní rozměry Dimension Dimensiones							Hmotnost Mass Peso kg	Základní únosnost Basic Load Rating Capacidad de carga elemental		Mezní únavové zátížení Fatigue stress limit Limite de fatiga de le carga Cu kN	Mezní frekv. otáč. Limiting Speed Velocidad lím. de giro para ng min-1
		d mm	D mm	B mm	rs min mm	ns mm	F mm	E mm		stat.	dyn.		
										Co kN	C kN		
100	NNU4920M	100	140	40	1,1	6,5	113	1,9	253	128	36	4810	
105	NNU4921M	105	145	40	1,1	6,5	118	2,0	261	130	32	4630	
110	NNU4922M	110	150	40	1,1	6,5	123	2,0	276	134	34	4460	
120	NNU4924M	120	165	45	1,1	6,5	134,5	2,9	341	175	42	4030	
130	NNU4926M	130	180	50	1,5	6,5	146	3,8	403	206	49	3680	
140	NNU4928M	140	190	50	1,5	6,5	156	4,1	430	213	53	3470	
150	NNU4930M	150	210	60	2	6,5	168,5	6,0	642	325	79	3130	
160	NNU4932M	160	220	60	2	6,5	178,5	6,4	666	329	82	2980	
170	NNU4934M	170	230	60	2	6,5	188,5	6,7	711	342	87	2840	
180	NNU4936M	180	250	69	2	9,5	202	6,7	944	450	116	2600	
190	NNU4938M	190	260	69	2	9,5	212	10,2	1006	467	123	2500	
200	NNU4940M	200	280	80	2,1	12,2	225	14,5	1155	547	141	2310	
220	NNU4944M	220	300	80	2,1	12,2	245	15,7	1234	564	151	2160	
240	NNU4948M	240	320	80	2,1	12,2	265	16,8	1314	580	161	2020	
260	NNU4952M	260	360	100	2,1	15	292	29,6	1983	870	209	1790	
280	NNU4956M	280	380	100	2,1	15	312	31,4	2109	898	223	1690	
300	NNU4960M	300	420	118	3	17,7	339	48,7	2665	1156	281	1520	
320	NNU4964M	320	440	118	3	17,7	359	53,6	2838	1196	300	1450	
340	NNU4968M	340	460	118	3	17,7	379	56,3	2929	1210	309	1390	
360	NNU4972M	360	480	118	3	17,7	399	59,2	3102	1248	328	1330	
380	NNU4976M	380	520	140	4	17,7	426	87,5	3971	1610	419	1230	
400	NNU4980M	400	540	140	4	17,7	446	91,7	4210	1665	445	1180	
420	NNU4984M	420	560	140	4	17,7	466	95,4	4336	1685	458	1140	
440	NNU4988M	440	600	160	4	17,7	490	133,0	5298	2082	560	1060	
460	NNU4992M	460	620	160	4	17,7	510	138,0	5607	2153	592	1020	
480	NNU4996M	480	650	170	5	17,7	534	163,0	6106	2347	645	980	
500	NNU49/500M	500	670	170	5	17,7	554	169,0	6285	2378	664	950	
530	NNU49/530M	530	710	180	5	17,7	585	201,0	8250	3064	742	890	
560	NNU49/560M	560	750	190	5	17,7	618	241,0	8860	3281	797	840	
600	NNU49/600M	600	800	200	5	17,7	666	282,0	10249	3602	922	770	
630	NNU49/630M	630	850	218	6	23,5	704	359,0	11393	4146	1025	740	
670	NNU49/670M	670	900	230	6	23,5	738	408,0	13868	5110	1248	700	
710	NNU49/710M	710	950	243	6	23,5	782	489,0	15893	5698	1430	660	
800	NNU49/800M	800	1060	258	6	23,5	880	626,0	17620	6234	1332	600	
850	NNU49/850M	850	1120	272	6	23,5	931	726,0	18000	6300	1435	500	
900	NNU49/900M	900	1180	280	6	23,5	986	817,0	20400	7100	1628	480	

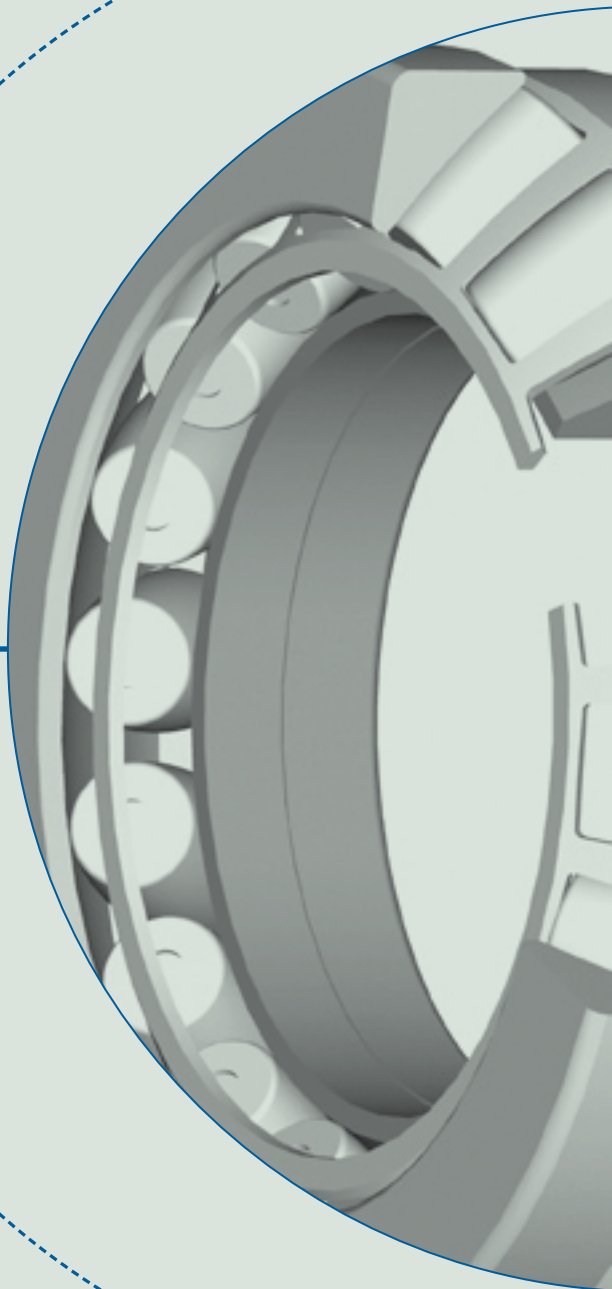

SPHERICAL ROLLER THRUST BEARINGS

SPHERICAL ROLLER THRUST BEARINGS

Spherical roller thrust bearings comprise a consistent, entire manufacturing program both in dimensional and design series 292, 293 and 294, being in compliance with the international standards ISO by their design and manufacturing process. Quality management system of the whole manufacturing process of spherical roller thrust bearings is certified according to international standards series 9000.

Contrary to other thrust bearings the spherical roller thrust bearings loads are transferred from one raceway to the other under certain angle; this enables to accommodate also radial load in addition to axial load. Spherical roller thrust bearings are separable, therefore the shaft ring with cage and spherical rollers and housing (outer) ring can be installed individually. Another important feature of these bearings is their ability to tilt, which allows the possibility of alignment of shaft deflection and of verticality deviation to the housing.

Spherical roller thrust bearings are produced, in dependence to size and type, in two designs – in standard and E design. Outstanding feature of bearings of E design are their higher utility parameters, they represent a new generation of spherical roller thrust bearings. Being of identical main dimensions, they have upper utility properties. Both designs can be produced with machined brass cage M or with steel sheet cage J. Should a bearing with machined brass cage, in which acting axial forces were accommodated also by housing for cage centering, be replaced by bearing with pressed steel sheet cage, a distance ring must be inserted between shaft ring and shaft shoulder.

The inner space of spherical roller thrust bearings can be efficiently utilized. Therefore they are suitable for accommodation of great load at relatively high speed frequency. The bearings are capable to accommodate in addition to axial load also certain radial forces, anyhow these must be of smaller value than 55 percent of simultaneously acting axial force. Housing ring spherical raceway enables to align verticality deviations between the shaft and housing.

For their high utility values the spherical roller thrust bearings find wide application in many fields and industrial sectors. They are mainly used in the following installations:

- medium and heavy-duty forming machines
- ship drive shafts
- drilling rigs of all types and sizes
- medium and heavy-duty cranes including crane hooks
- pumps of medium and large sizes and capacities
- mining tunnelling machines and mining engineering
- heavy load swivelling turntables of installations in open pit mines and stone quarries
- power plant engineering (turbines, generating sets, electric motors).

Designation of Spherical Roller Thrust Bearings

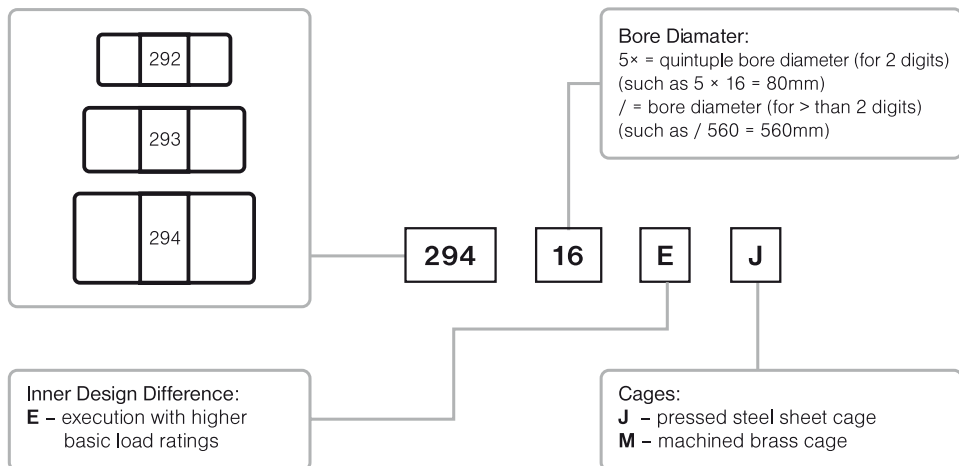

Boundary Dimensions

Boundary dimensions of spherical roller thrust bearings shown in dimensional tables comply with international dimensional plan ISO.

Self Alignment

Design of spherical roller thrust bearings allows tilting and thus alignment of shaft verticality deviation to rolling elements, while shaft deflection (to certain magnitude) has no influence on bearing operation. Under normal acting load $F_a + 2,7 \cdot F_r = 0,05 \cdot C_{oa}$, shaft ring rotation, constant verticality deviations and usual operating conditions the tilting of spherical roller thrust bearings off central position is allowed by values shown in the table, without impairing their correct function:

Bearing Type	Permitted Tilting
292	2°
293	2°30'
294	3°

Under growing load the permitted tilting diminishes. For instance, under load $F_a + 2,7 \cdot F_r = 0,15 \cdot C_{oa}$ the permitted tilting of all bearing types is approx. 1.5°. Taking advantage of permitted tilting depends also on sealing type and arrangement design.

Cages

Spherical roller thrust bearings in standard version have machined brass cages centered by shaft ring steel bush and bear designation **M**. The version with steel sheet cage centered by shaft ring are marked by letter **J**. Spherical roller thrust bearings with steel sheet cage are interchangeable with bearings with brass cage, anyhow, when replacing brass cage bearings with bearings with steel sheet cage bearings it is necessary to use distance rings (see drawing in tabular part).

Review of Bearings Executions

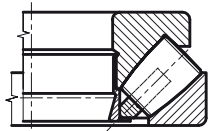

Types M, EM

- M** Standard bearing version with machined brass cage centered by shaft ring steel guiding bush
- EM** Bearing with better utilized inner space with higher utility parameters, with machined brass cage centered by shaft ring steel guiding bush

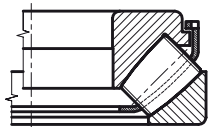

Types J, EJ

- J** Standard bearing version with steel sheet cage centered by shaft ring
- EJ** Bearing with better utilized inner space with higher utility parameters, with steel sheet cage centered by shaft ring

Connecting Dimensions

Bearing rings may bear only on facial resting surface on shaft or in housing but not on the transient rounding. Maximum radius of connected parts $r_{a\text{ma}}$ must therefore be smaller than the minimum dimension of bearing rings rounding r_s .

Tolerance

Spherical roller thrust bearings are generally manufactured in normal tolerance class **PO** (this symbol is not shown in the designation). The limiting tolerance values are shown in ISO 492. Production of bearings of higher tolerance class needs to be negotiated with the manufacturer.

Operating Temperature Effect on Bearings Material

All ZKL spherical roller thrust bearings pass special heat treatment permitting their use under operating temperature up to +200 °C without inadmissible dimensional changes.

Design of Connecting Parts

Connecting dimensions d_a and D_a shown in dimensional tables apply for loads up to $F_a = 0.1 \cdot C_{oa}$. Should a greater load act on the bearing, we recommend to rest both the shaft and housing rings by rings entire facial surfaces ($d_a = d_1$, $D_a = D_1$) and simultaneously to support the housing ring radially too. In such cases it is desirable to contact the technical and Consulting Services department of ZKL – Vyzkum a vyvoj, a. s. for advice. When using the bearings of **J**, **EJ** design with steel sheet cages it is appropriate to enlarge the housing bore near to the cage to prevent thus contact of housing with cage at bearing tilt. Recommended diameter value of this recess is $D + 15$ mm for bearings of outer diameter up to 380 mm (inclusive) and $D + 20$ mm for larger bearings.

Lubrication

We recommend to generally lubricate spherical roller thrust bearings by oil. Only under very low speed frequency and small load, when bearings with steel sheet cage are used, lubrication by grease may be chosen. When using grease, the shaft in horizontal position is more suitable than vertical. The permissible speed frequency of vertically oriented shaft lubricated by grease is just a half of a shaft positioned horizontally. The inner design of spherical roller thrust bearings develops a pumping effect under operation, which can be found useful under specific circumstances and which should be taken in consideration when designing the lubrication and sealing

Oil Viscosity for Spherical Roller Thrust Bearings	
d · n	Oil Kinematic Viscosity at 40 °C [mm ² ·s ⁻¹]
1000	250 ÷ 550
10000	100 ÷ 550
100000	45 ÷ 100
200000	30 ÷ 80

Minimum Load

Rolling bearings under operation must be exposed to certain minimum load to secure their satisfactory operation. This applies to spherical roller thrust bearings as well and particularly for operation at higher speeds, when inertial forces of spherical rollers and of cage, plus friction in lubricant may have adverse influence on rolling and may result in damage of rings raceways and of spherical rollers by slipping.

The needed minimum load for such cases can be estimated from this relation:

$$F_{am} = 1.8 \cdot F_r + M \cdot \left(\frac{n}{1000} \right)$$

where

- F_{am} ... minimum axial load [N]
- F_r ... radial element of acting combined load [N]
- M ... minimum load coefficient – see bearing tables
- n ... speed frequency [min⁻¹]

If $1.8 \cdot F_r < 0,0005 \cdot C_{oa}$, it is necessary to substitute in the above equation $1.8 \cdot F_r$ by $0.0005 \cdot C_{oa}$.

C_{oa} ... basic static load rating [N]

As a rule the mass of parts accommodated by the bearing along with external acting forces exceed the required minimum load. Should it not be the case, the bearing must be loaded by a supplementary force, such as by springs.

Equivalent Dynamic Load

Spherical roller thrust bearings can accommodate also radial load in a certain extent, but only under a simultaneously acting axial load. On condition that $F_r \leq 0.55 \cdot F_a$, it is established that

$$P_{ea} = F_a + 1.2 \cdot F_r$$

where

P_{ea} . . . equivalent dynamic load [N]
 F_a . . . axial load [N]
 F_r . . . radial load [N]

If the mounting is arranged so that the axial and radial run-outs can be aligned by relative motions between rings, and provided that

$$F_r \leq 0.55 \cdot F_a \quad \text{potom } P_{ea} = 0.88 \cdot (F_a + 1.2 \cdot F_r)$$

If $F_r > 0.55 F_a$, please kindly contact Technical and Consulting Services department of ZKL – Vyzkum a vyvoj, a. s., who can suggest a suitable solution of the problem.

Equivalent Static Load

For spherical roller thrust bearings it is established (on condition that $F_r \leq 0.55 \cdot F_a$) that

$$P_{oae} = F_a + 2.7 \cdot F_r$$

If $F_r > 0.55 F_a$, please kindly contact Technical and Consulting Services department of ZKL – Vyzkum a vyvoj, a. s., who can suggest a suitable solution of the problem.

SPHERICAL ROLLER THRUST BEARINGS

d = 50 to 110 mm

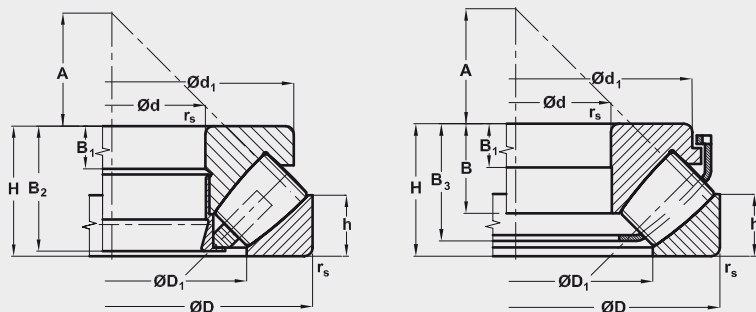

Boundary Dimensions				Mass	Basic Load Rating		Minimum Axial Load Coefficient	Limiting Speed Frequency for Oil Lubrication	Bearing Designation
d	D	H	r _s		Dynamic	Static			
			min		c _a	c _{0a}	M		
mm				kg	kN		min ⁻¹		
50	110	36	1.5	1.67	290	930	0.11	3100	29410EJ
60	130	42	1.2	2.47	382	1004	0.13	2600	29412EJ
60	130	42	1.5	2.6	287	809	0.082	2400	29412M*
65	140	45	2	3.26	434	1155	0.14	2400	29413EJ
65	140	45	2	3.3	340	973	0.12	2200	29413M*
70	150	48	2	3.98	464	1268	0.16	2200	29414EJ
70	150	48	2	4	371	1070	0.14	2000	29414M*
75	160	51	2	4.9	524	1465	0.18	2200	29415EJ
75	160	51	2	4.9	429	1250	0.2	2000	29415M*
80	170	54	2.1	5.8	570	1430	0.26	2000	29416EJ
80	170	54	2.1	5.8	464	1370	0.23	1900	29416M*
85	180	58	2	6.67	692	1945	0.24	1800	29417EJ
85	180	58	2.1	6.9	527	1570	0.31	1800	29417M*
90	190	60	2.1	7.77	703	2172	0.4	1800	29418EJ
90	190	60	2.1	8.1	578	1780	0.4	1700	29418M*
100	170	42	1.5	3.95	436	1400	0.58	2000	29320EJ
100	210	67	2.5	10.8	865	2578	0.59	1600	29420EJ
100	210	67	3	11.8	705	2170	0.59	1500	29420M*
110	190	48	2	5.4	570	1760	0.39	1600	29322EJ
110	190	48	2	5.5	442	1420	0.25	1600	29322M*
110	230	73	2.5	13.5	1022	3078	0.85	1400	29422EJ
110	230	73	3	14.5	817	2600	0.85	1400	29422M*

Notice: Deliveries of bearings marked * need to be negotiated with manufacturer

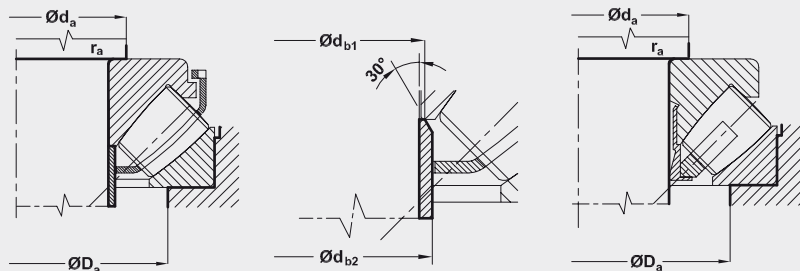

Dimensions									Connecting Dimensions				
d	d _i	D _i	B	B ₂	B ₁	B _a	h	A	d _a min	D _a max	r _a max	d _{b1} max	d _{b2} max
mm									mm				
50	95	70	25		13	32	20.5	32	70	90	1.5	56	60.5
60	118	87	27		27	37	20	38	90	117	1.5	67	67
60	118	88		39.5	15		20	38	90	109	1.5		
65	128	93	29.5		16	39	21	42	100	118	2	72	72
65	128	96.5		42.5	16		21	42	100	118	2		
70	137	101	31		17	42.5	23	44	105	126	2	77.5	77.5
70	137	102		45.5	17		23	44	105	126	2		
75	146	108	33.5		18	47	24	47	115	134	2	82.5	82.5
75	146	109		48	18		24	47	115	134	2		
80	155	116	36		19	46.5	24	50	120	141	2	86	95.5
80	155	116		51	19		24	50	120	141	2		
85	164	123	37		21	50	28	54	130	153	2	94	94
85	164	125		55	21		28	54	130	153	2		
90	174	130	39		22	53	29	56	135	161	2	99	99
90	174	130		57	22		29	56	135	161	2		
100	150	128	26.2		15	37.3	20.5	58	130	147	1.5	107	107
100	193	144	53		24	58	32	62	150	175	3	110	110
100	193	144.5		64	24		32	62	150	178	2.5		
110	176	143	31		16	42	23	64	145	165	2	113	119.5
110	176	143		45.5	16		23	64	145	165	2		
110	209,5	159	47	0	27	64	35	69	165	193	3	120.5	129
110	212	160		69	26		35	69	165	196	2.5		

SPHERICAL ROLLER THRUST BEARINGS

d = 120 to 200 mm

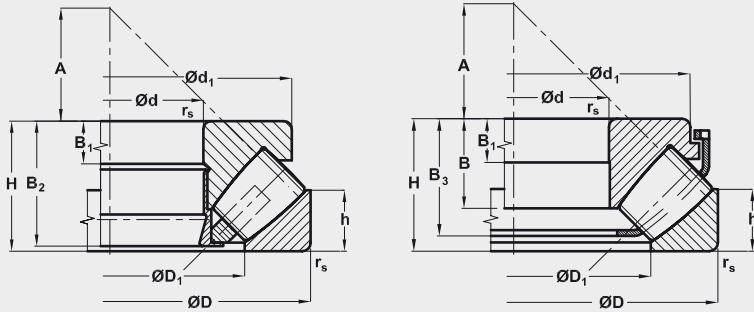

Boundary Dimensions				Mass	Basic Load Rating		Minimum Axial Load Coefficient	Limiting Speed Frequency for Oil Lubrication	Bearing Designation
d	D	H	r _s		Dynamic	Static			
			min		c _a	c _{oa}	M		
mm				kg	kN		min ⁻¹		
120	210	54	2.1	7.41	680	2500	0.78	1600	29324EJ
120	210	54	2.1	7.6	560	1830	0.42	1400	29324M*
120	250	78	4	17.5	1180	3590	0.91	1300	29424EJ
120	250	78	4	18.1	934	3000	0.91	1300	29424M*
130	225	58	2.1	9.08	765	2950	1.1	1500	29326EJ
130	225	58	2.1	9.3	628	2070	0.54	1300	29326M*
130	270	85	4	21.6	1395	4300	1.6	1200	29426EJ
130	270	85	4	22.5	1090	3540	1.6	1200	29426M*
140	240	60	2.1	10.5	850	3150	1.2	1400	29328EJ
140	240	60	2.1	11	675	2310	0.67	1300	29328M*
140	280	85	4	23	1509	4686	1.8	1200	29428EJ
140	280	85	4	24.2	1130	3750	1.8	1200	29428M*
150	250	60	2.1	10.9	863	3236	1.3	1400	29330EJ
150	250	60	2.1	11.5	697	2430	0.74	1200	29330M*
150	300	90	4	28	1626	5241	2.3	1100	29430EJ
150	300	90	4	29.4	1280	4270	2.3	1100	29430M*
160	270	67	3	14.4	1036	3977	2	1200	29332EJ
160	270	67	3	15.2	807	2810	0.99	1100	29332M*
160	320	95	5	33.3	1800	6550	5.4	1000	29432EJ
160	320	95	5	35.5	1460	4810	2.9	1000	29432M*
170	280	67	3	15.1	1058	4098	2.1	1200	29334EJ
170	280	67	3	16	833	2950	1.1	1100	29334M*
170	340	103	5	43.7	1620	5380	3.6	940	29434M
180	300	73	3	19.1	1243	4813	2.9	1100	29336 EJ
180	300	73	3	20.3	984	3530	1.6	1000	29336M*
180	360	109	5	52	1800	6010	4.5	890	29436M
190	320	78	4	23.3	1440	4840	2.9	1100	29338EJ
190	320	78	4	24.8	1120	4010	2	940	29338M*
190	380	115	5	60	1960	6610	5.5	840	29438M
200	280	48	2.1	8.76	710	3150	1.4	1150	29240EM
200	340	85	4	29	1620	5480	3.8	950	29340EJ
200	340	85	4	33	1300	4740	2.8	890	29340M*
200	400	122	5	69	2210	7510	7.1	790	29440M

Notice: Deliveries of bearings marked * need to be negotiated with manufacturer

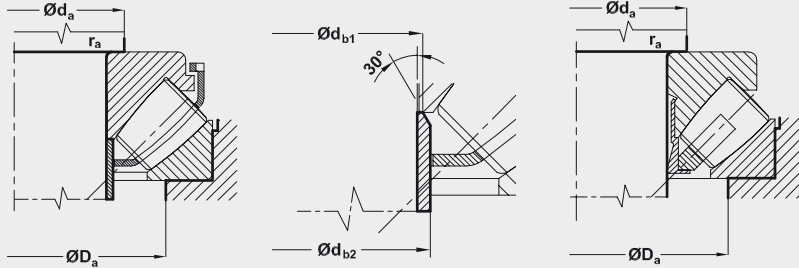

Dimensions										Connecting Dimensions				
d	d _i	D _i	B	B ₂	B ₁	B _a	h	A		d _a	D _a	r _a	d _{b1}	d _{b2}
mm										min	max	max	max	max
mm										mm				
120	187.1	155.5	35.5		19	47	27	70		160	181	2	128	128
120	194	157.5		51	18		26	70		160	184	2		
120	226.8	173	50.5		29	69.5	37	74		180	209	3	132	143
120	229	172		74	29		37	74		180	212	3		
130	201.5	165.7	37.5		21	49.6	30.1	76		175	194	2	138	143
130	205	170		55	19		28	76		170	198	2		
130	245	188	54		31	74	41	81		195	227	3	142.5	153
130	247	188		81	31		41	81		195	229	3		
140	214.9	178.9	38.5		22	52.4	30	82		185	208	2	148	154
140	219	183		57	20		29	82		185	211	2		
140	254	196.5	54		32	74	41	86		205	239	3	157	166
140	257	197.5		81	31		41	86		205	239	3		
150	222.5	189.6	38		22	53.8	28	87		195	219	2	158	163
150	229	193		57	20		29	87		195	222	2		
150	273	209.5	58		34	79	44	92		220	253	3	163	175
150	276	211.5		86	32		44	92		220	257	3		
160	243.6	202.3	42		24	58.6	33	92		210	235	2.5	169	176
160	248	207		64	23		32	92		210	239	2.5		
160	282.8	221.7	60.5		35	82	45.5	99		235	270	4	175	189
160	306	226		91	34		45	99		230	274	4		
170	253.6	214.6	42.2		24	60	32	96		220	245	2.5	178	188
170	258	215		64	23		32	96		220	248	2.5		
170	324	240		99	37		50	104		245	291	4		
180	270.4	228.3	46		26	64.3	35.5	103		235	262	2.5	189	195
180	277	231		69	25		35	103		235	266	2.5		
180	342	255		105	39		52	110		260	307	4		
190	284.4	239.5	49		28	68	36	110		250	280	3	200	211
190	308	246		74	27		38	110		250	283	3		
190	360	270		111	41		55	117		275	325	4		
200	264	233	32		45	17	24	108		235	260	2		
200	302.8	253.6	53.5		29	73	40	116		265	297	3	211	224
200	325	261		81	29		41	116		265	300	3		
200	380	284		117	43		59	122		290	343	4		

SPHERICAL ROLLER THRUST BEARINGS

d = 220 to 320 mm

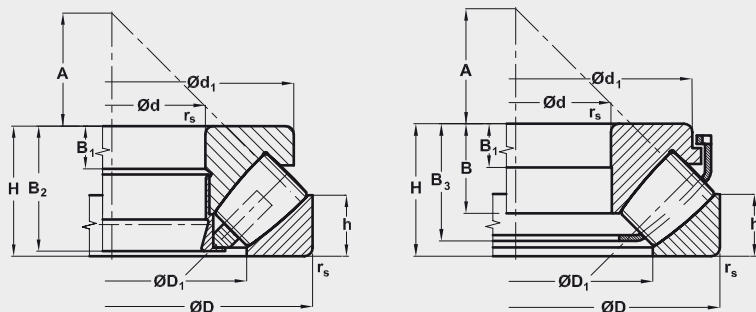

Boundary Dimensions				Mass	Basic Load Rating		Minimum Axial Load Coefficient	Limiting Speed Frequency for Oil Lubrication	Bearing Designation
d	D	H	r _s		Dynamic	Static			
			min		c _a	c _{0a}	M		
mm				kg	kN			min ⁻¹	
220	300	48	2	9.64	735	3350	1.4	1300	29244EM
220	360	85	4	31.6	1740	6300	5	950	29344EJ
220	360	85	4	32.8	1340	4970	3.1	840	29344M*
220	420	122	6	74	2260	7970	7.9	750	29444M
240	340	60	2.1	16.7	770	3450	1.5	890	29248M
240	380	85	4	33.4	1790	6490	5.3	900	29348EJ
240	380	85	4	35.3	1340	5190	3.4	790	29348M*
240	440	122	6	79	2340	8420	8.9	750	29448M
260	360	60	2.1	18.5	801	3650	1.7	890	29252M
260	420	95	5	46.9	2240	8310	8.6	800	29352EJ
260	420	95	5	48.5	1780	6820	5.8	750	29352M*
260	480	132	6	105	2730	9870	12	670	29452M
280	380	60	2.1	19.5	847	3950	2	840	29256M
280	440	95	5	49.5	2310	8490	9	800	29356EJ
280	440	95	5	52.5	1780	7100	6.3	710	29356M*
280	520	145	6	127	4470	15750	31	650	29456EJ
280	520	145	6	132	3230	11840	18	630	29456M*
300	420	73	3	30.5	1030	4670	2.7	750	29260M
300	480	109	5	68.7	2650	11000	15	700	29360EJ
300	480	109	5	74	2180	8500	9	630	29360M*
300	540	145	6	133	4510	16460	34	630	29460EJ
300	540	145	6	140	3220	11850	18	600	29460M*
320	440	73	3	32.9	1070	4930	3	710	29264M
320	500	109	5	72.1	2850	10920	15	670	29364EJ
320	500	109	5	77	2180	8850	9.8	630	29364M*
320	580	155	7.5	164	5010	21200	56	600	29464EJ
320	580	155	7.5	164	3890	14690	27	560	29464M*

Notice: Deliveries of bearings marked * need to be negotiated with manufacturer

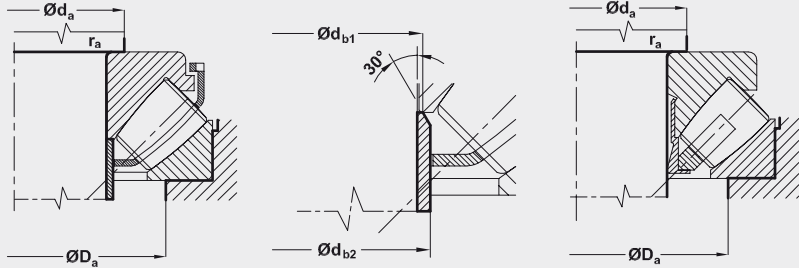

Dimensions									Connecting Dimensions				
d	d _i	D _i	B	B ₂	B ₁	B _a	h	A	d _a min	D _a max	r _a max	d _{b1} max	d _{b2} max
mm									mm				
220	286	252		46	17		24	117	285	260	2		
220	324.4	273	55		29	74	41	125	285	316	3	229	240
220	345	280		81	29		41	125	285	320	3		
220	400	305		117	43		58	132	310	364	5		
240	330	283		57	19		30	130	285	311	2		
240	343.7	294.8	54		29	75	40.5	135	305	336	3	249	259
240	365	300		81	29		41	135	300	340	3		
240	420	321		117	43		59	142	330	383	5		
260	350	302		57	19		30	139	305	331	2		
260	380.3	320.4	61		32	84	46	148	3350	370	4	273	286
260	405	325		91	32		45	148	330	374	3		
260	460	346		127	48		64	154	360	419	5		
280	370	323		57	19		30	150	325	351	2		
280	401.7	342.1	62		32	84	45	158	355	390	4	293	305
280	423	345		91	32		46	158	350	394	4		
280	468.9	370	95		52	125	70	166	395	446	5	300	320
280	495	380		140	52		68	166	390	453	5		
300	405	355		69	21		38	162	355	386	2.5		
300	431.9	366.7	70		36	95	51	168	385	423	4	313	329
300	460	375		105	37		50	168	380	429	4		
300	489.2	370	95		55	125	70	175	415	465	5	319	340
300	515	398		140	52		70	175	410	471	5		
320	430	375		69	21		38	172	375	406	2.5		
320	456.1	387	68		37	95	53	180	405	442	4	332	347
320	482	395		105	37		53	180	400	449	4		
320	525.6	422	102		55	134	74.5	191	450	500	6	344	367
320	555	430		149	55		75	191	435	507	6		

SPHERICAL ROLLER THRUST BEARINGS

d = 340 to 800 mm

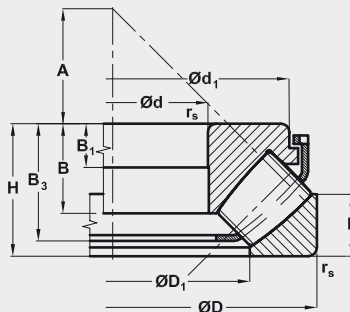
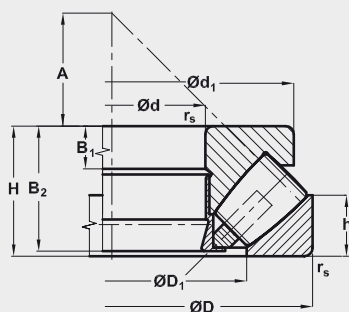

Boundary Dimensions				Mass	Basic Load Rating		Minimum Axial Load Coefficient	Limiting Speed Frequency for Oil Lubrication	Bearing Designation
d	D	H	r _s		Dynamic	Static			
			min		c _a	c _{0a}	M		
mm				kg	kN			min ⁻¹	
340	540	122	5	103	2640	10550	14	560	29368M
340	620	170	7.5	211	5820	25080	66	380	29468EJ
340	620	170	7.5	218	4350	16410	34	500	29468M*
360	500	85	4	51.8	1400	6600	5.4	630	29272M
360	560	122	5	107	2650	11030	15	560	29372M
380	520	85	4	52.8	1550	7510	7.1	600	29276M
380	670	175	7.5	263	4700	19100	46	490	29476EM
400	540	85	4	55.3	1600	7900	7.8	600	29280M
400	620	132	6	150	3290	14120	25	500	29380M
400	506	185	7.5	306	6810	26500	88	450	29480EM
420	650	140	6	170	3410	14700	27	450	29384M
420	730	185	7,5	308	6850	31020	63	430	29484EM
440	680	145	6	190	3860	16850	35	450	29388M
440	780	206	9.5	407	6280	24650	76	400	29488M
480	850	224	9.5	518	9646	44398	82	340	29496EM
500	670	103	5	101	2400	12120	18	470	292/500M
500	750	150	6	220	4220	18660	44	400	293/500M
500	870	224	9,5	548	10025	48568	290	340	294/500 EM
530	800	160	7.5	286	5130	22730	65	380	293/530M
600	900	180	7.5	390	6800	31500	120	330	293/600EM
630	850	132	6	211	4250	22500	63	350	292/630M
800	1360	335	15	2010	16340	72360	650	220	294/800M

Notice: Deliveries of bearings marked * need to be negotiated with manufacturer

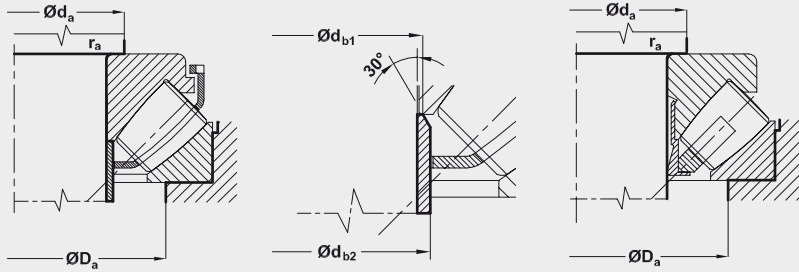

Dimensions										Connecting Dimensions				
d	d _i	D _i	B	B ₂	B ₁	B _a	h	A		d _a min	D _a max	r _a max	d _{b1} max	d _{b2} max
mm										mm				
340	520	424		117	41		59	192		430	484	4		
340	561.8	442.2	112		54	146	84	201		475	530	6		
340	590	452		164	61		82	201		465	451	6		
360	485	420		81	25		44	194		420	461	3		
360	540	444		117	41		59	202		450	504	4		
380	505	440		81	27		42	202		440	480	3		
380	622	504		168	63		85	222		504	570	6		
400	526	460		81	27		42	212		460	500	3		
400	596	494		127	44		64	225		498	557	5		
400	651	530		178	67		89,5	234		550	615	6		
420	626	520		135	48		68	235		523	585	5		
420	663	540		175	67		90	244		592	684	8		
440	655	546		140	49		70	245		548	614	5		
440	745	576		199	74		100	260		592	684	8		
480	772	611.6		214	81		108	280		660	735	8		
500	654	574		99	33		55	268		578	622	4		
500	725	611		144	51		74	280		613	680	5		
801	625,6			218	81		110	290		685	755	8		
530	772	648		154	54		76	295		651	724	6		
600	850	731		171	64		87	335		735	815	6		
630	820	724		127	42		67	338		730	789	5		
800	1300	1040		324	120		162	462		1055	1200	12		

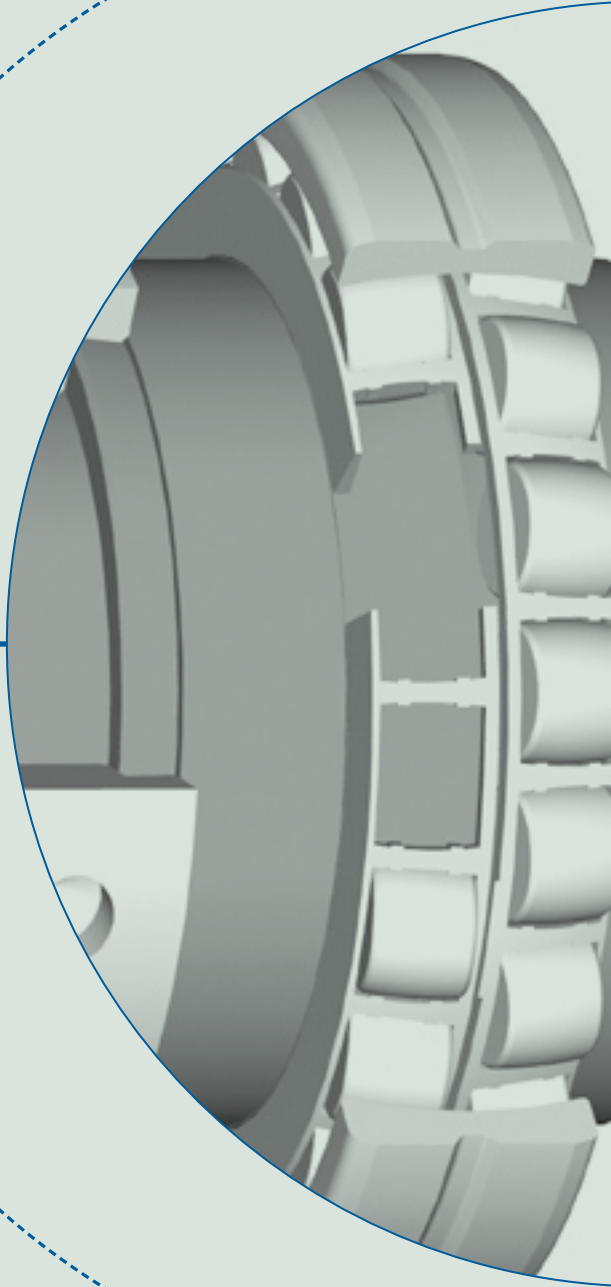

SPECIAL BEARINGS

SPECIAL BEARINGS



In addition to standard assortment of bearings specified in this Group catalogue the production in ZKL Group gradually expanded by a number of special bearings based on clients' requirements and on industrial sectors development.

These are standardized bearings for special machines and use developed and produced on clients' wishes and requirements upon consultations with professionals in bearings design and manufacture.

By virtue of lasting experiences ZKL Group is continuously prepared to render assistance to its existing and new clients by its development base, ZKL – Vyzkum a vyvoj, a. s., in professional advisory and consulting services in the fields of design, mounting, technical parameters calculation, as well as in all requirements of new bearings development.

SPECIAL BEARINGS

PLC 59-10

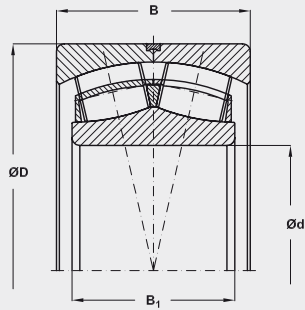

Boundary Dimensions				Basic Load Rating		Mass	Bearing Designation
				Dynamic C_r	Static C_{or}		
d	D	B	B_1				
mm				kN		kg	
110	180	82	69	501	839	7.7	PLC 59-10

Bearing with Extended Outer Ring for Tilting Angles up to 6°.

PLC 58-11

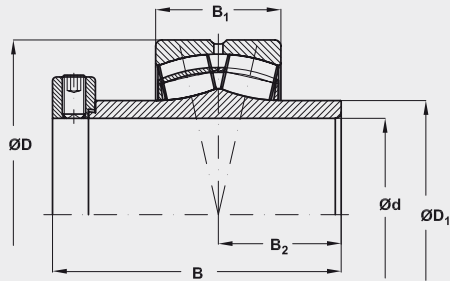

Boundary Dimensions						Basic Load Rating		Mass	Bearing Designation
						Dynamic C_r	Static C_{or}		
d	D	D_1	B_1	B_2	B				
mm						kN		kg	
74.6	120	88,34	31	31,8	92	196	255	3.0	PLC 58-11

Clamping Spherical Roller Bearing Designed for Agricultural Machinery and Conveyors.

PLC 58-9-1

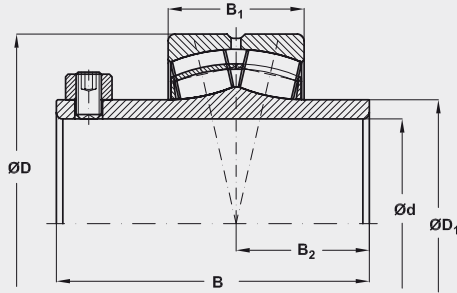

Boundary Dimensions						Basic Load Rating		Mass	Bearing Designation
d	D	D ₁	B ₁	B ₂	B	Dynamic C _r	Static C _{0r}		
mm						kN		kg	
76.2	130	88.71	31	31.75	92.2	196	255	3.1	PLC 58-9-1

Clamping Spherical Roller Bearing Designed for Agricultural Machinery and Conveyors.

SPECIAL BEARINGS

PLC 412-8, PLC 412-7, PLC 411-27, PLC 411-27-1

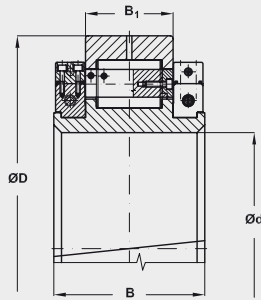

Boundary Dimensions				Basic Load Rating		Mass	Bearing Designation
d	D	B	B ₁	Dynamic C _r	Static C _{0r}		
mm				kN		kg	
320	622.37	272	160.4	3100	4950	353.0	PLC 412-8
240	440.07	156	90.5	1248	1920	92.0	PLC 412-7
220	393.76	156	90.5	1200	1760	83.0	PLC 411-27
218	393.76	156	90.5	1200	1760	83.8	PLC 411-27-1

Cylindrical Roller Bearing Split in Shaft Axis Designed for Rolling Mills.

PLC 010-3

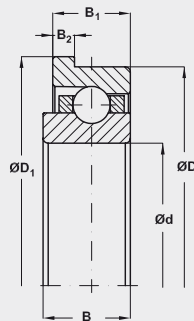

Boundary Dimensions						Basic Load Rating		Mass	Bearing Designation
d	D	D ₁	B ₁	B ₂	B	Dynamic C _r	Static C _{0r}		
mm						kN		kg	
140	215	225	38.1	10.71	42.86	116	139	5.3	PLC 010-3

Special Ball Bearing.

KL 761

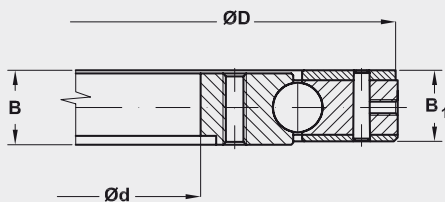

Boundary Dimensions				Basic Load Rating		Mass	Bearing Designation
				Dynamic C_r	Static C_{or}		
d	D	B	B_1				
mm				kN		kg	
559	761	38.2	36.5	232	425	51.3	KL 761

Special Ball Bearing for Debarking Machines in Wood-Working Industry.

PLC 58-2

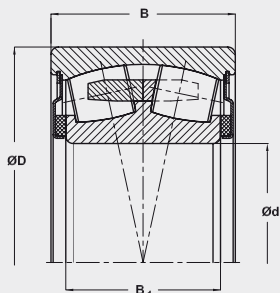

Boundary Dimensions				Basic Load Rating		Mass	Bearing Designation
				Dynamic C_r	Static C_{or}		
d	D	B	B_1				
mm				kN		kg	
65	158.8	70	48	212	250	7.36	PLC 58-2

Bearing with Sheet Metal Shields and Seals.

SPECIAL BEARINGS

PLC 58-6

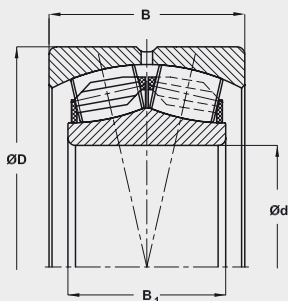

Boundary Dimensions				Basic Load Rating		Mass	Bearing Designation
				Dynamic	Static		
d	D	B	B ₁	C _r	C _{or}		
mm				kN		kg	
100	150	62	50	310	550	3.7	PLC 58-6

Double Row Spherical Roller Bearing of Greater Tilting Angle, for Mounting of Transmission Box of Mobile Concrete Mixers. Polyamide Cage.

PLC 59-5

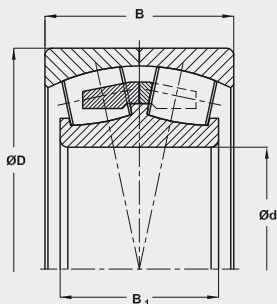

Boundary Dimensions				Basic Load Rating		Mass	Bearing Designation
				Dynamic	Static		
d	D	B	B ₁	C _r	C _{or}		
mm				kN		kg	
100	180	82	69	480	710	10.3	PLC 59-5

Double Row Spherical Roller Bearing of Greater Tilting Angle, for Mounting of Transmission Box of Mobile Concrete Mixers.

PLC 59-7

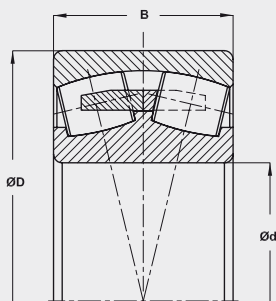

Boundary Dimensions			Basic Load Rating		Mass	Bearing Designation
d	D	B	Dynamic C_r	Static C_{Or}		
mm			kN		kg	
130	220	73	570	1080	12.2	PLC 59-7

Double Row Spherical Roller Bearing Made to UIC Dimensional Plan, for Mounting of Railway Vehicle Axles with Journal Diameter of 130 mm.

PLC 510-9

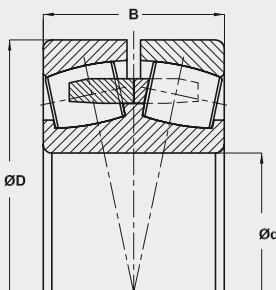

Boundary Dimensions			Basic Load Rating		Mass	Bearing Designation
d	D	B	Dynamic C_r	Static C_{Or}		
mm			kN		kg	
130	225	80	570	1080	12.2	PLC 510-9

Double Row Spherical Roller Bearing with Split Outer Ring.

SPECIAL BEARINGS

PLC 512-5

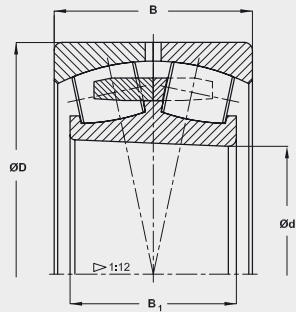

Boundary Dimensions				Basic Load Rating		Mass	Bearing Designation
				Dynamic C_r	Static C_{or}		
d	D	B	B_1				
mm				kN		kg	
440	720	270	226	4300	9000	389.0	PLC 512-5

Double Row Spherical Roller Bearing with Split and Extended Outer Ring for Greater Tilting Angles

PLC 512-28

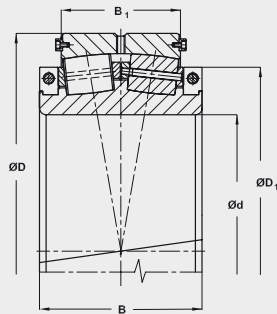

Boundary Dimensions					Basic Load Rating		Mass	Bearing Designation
					Dynamic C_r	Static C_{or}		
d	D	D_1	B	B_1				
mm					kN		kg	
950	1250	1125	300	220	6400	20000	987	PLC 512-28

Split Double Row Spherical Roller Bearing, for Mounting of Converter

VVSL 4084L

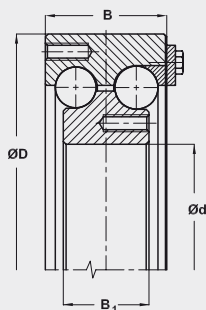

Boundary Dimensions				Basic Load Rating		Mass	Bearing Designation
				Dynamic	Static		
d	D	B	B ₁	C _a	C _{0a}		
mm				kN		kg	
860.5	1014.8	85	60	600	3450	118.0	VVSL 4084L

Double Row Ball Bearing for Precision Mounting of Machine Tool Turntable.

VVSL 41348L

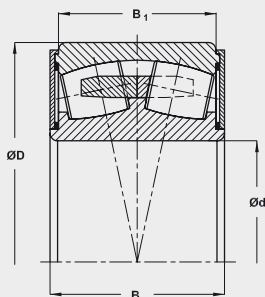

Boundary Dimensions				Basic Load Rating		Mass	Bearing Designation
				Dynamic	Static		
d	D	B	B ₁	C _r	C _{0r}		
mm				kN		kg	
90	220	118	93	785	950	23.0	VVSL41348L

Double Row Spherical Roller Bearing with Shields and Seals.

SPECIAL BEARINGS

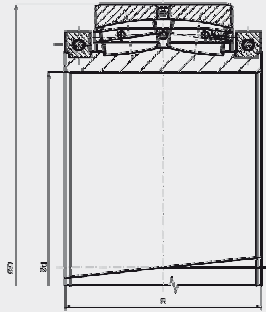

Bearing designation	Boundary Dimensions			Basic Load Rating		Mass
	d	D	H	Dynamic Cr	Static Co	
				kN		Kg
PLC 512-37	750	1000	360	6380	17230	1220
Double Row Spherical Roller Bearing with Split Outer Ring for ladder excavator						

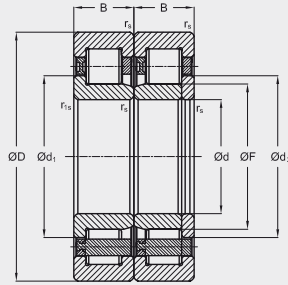

Bearing Designation	Boundary Dimensions								Basic load rating Capacidad		Max. speed of railway car	Radial clearance		Axial clearance		Precision class
	d	D	B	r _{min}	r _{1min}	d ₁	d ₂	F	dyn. C _r	stat. C _{sc}		Min.	Max.	Min.	Max.	
	mm								kN		km h ⁻¹	mm				
PLC 410-13	120	240	80	3	7,5	160,8		150	553	742	160	0,120	0,160	0,300	0,900	P0
PLC 410-14	120	240	80	3	7,5		160,8	150	553	742	160	0,120	0,160	0,300	0,900	P0
PLC 410-15	130	240	80	3	7,5	170,5		159	517	752	160	0,135	0,180	0,300	0,900	P0
PLC 410-16	130	240	80	3	7,5		170,5	159	517	752	160	0,135	0,180	0,300	0,900	P0

Special Single Row Radial Cylindrical Roller Bearings
For Railway Rolling Stock Axles

SPECIAL BEARINGS

PLC 412-11

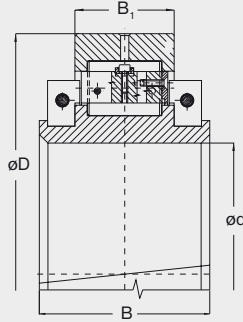

Boundary Dimensions				Basic Load Rating		Mass	Bearing Designation
				Dynamic	Static		
d	D	B	B ₁	C _r	C _{or}		
mm				kN		kg	
260	431,8	170	96,8	1140	1940	86,5	PLC 412-11

Cylindrical Roller Bearing Split in Shaft Axis Designed for Rolling Mills.

PLC 510-20

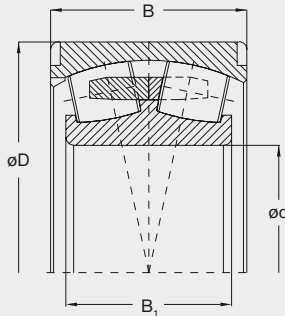

Boundary Dimensions				Basic Load Rating		Mass	Bearing Designation
				Dynamic	Static		
d	D	B	B ₁	C _r	C _{or}		
mm				kN		kg	
111,16	215	90	76	564	803	14,4	PLC 510-20

Double Row Spherical Roller Bearing with Split and Extended Outer Ring for Greater Tilting Angles